

INSTALLATION MANUAL

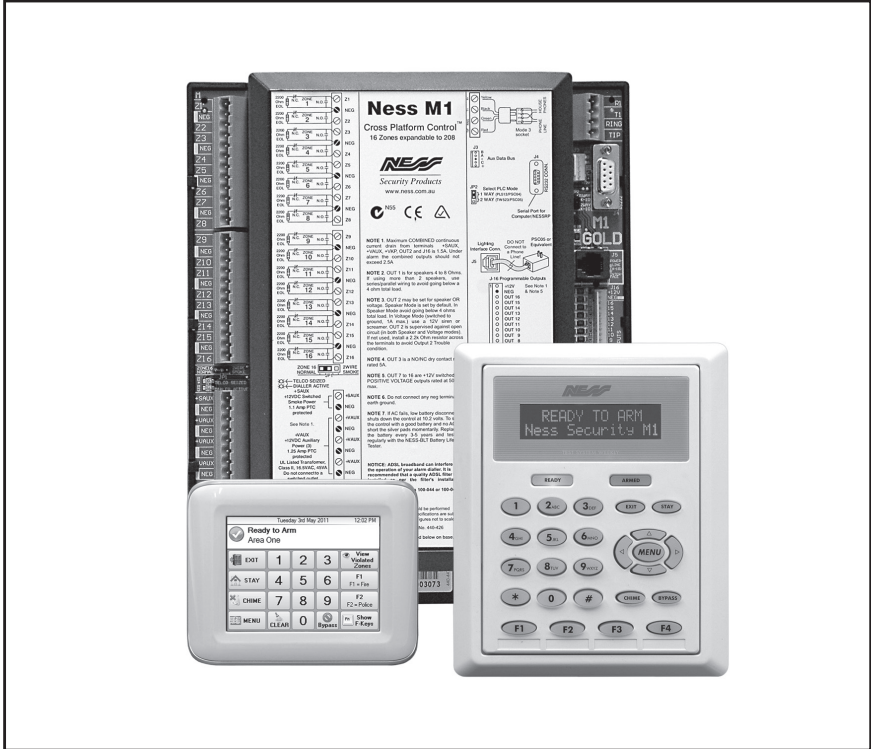

M1 Cross Platform Control™

Specifications, Installation and programming



Introduction

LIMITATION

The NESS ELK-M1G and ELK-M1 Controls are designed to warn against unauthorized entry and other situations. However, it is not a guarantee of protection against the occurrence of burglary, fire, or other emergency. Any alarm system is subject to compromise or failure to warn for various reasons. For example:

- Unauthorized access can be gained through unprotected points or by disarming or bypassing protected points.
- Sensing devices are power driven and do not operate without electrical power. Battery-operated devices will not work without batteries, with dead batteries, or if the batteries are not put in properly. Devices powered solely by AC will not work if their AC power supply is cut off for any reason, however briefly.
- Telephone lines over which alarm signals are transmitted may be out of service or rendered inoperable by an intruder.
- Even if the system responds to the emergency as intended, occupants may have insufficient time to protect themselves from the emergency situation. In the case of a monitored alarm system, authorities may not respond appropriately.
- Smoke detectors have limitations and cannot detect all types of fires. According to data published by the Federal Emergency Management Agency, while smoke detectors have played a key role in reducing residential fire deaths in Australia, they may not activate or provide early warning for a variety of reasons in as many as 35% of all fires. Some of the reasons some detectors used in conjunction with this System may not work are as follows. Smoke detectors may have been improperly installed and positioned. Smoke detectors may not sense fires that start where smoke cannot reach the detectors, such as in chimneys, in walls, or roofs, or on the other side of closed doors. Smoke detectors also may not sense a fire on another level of a residence or building. A second floor detector, for example, may not sense a first floor or basement fire. Finally, smoke detectors have sensing limitations. No smoke detector can sense every kind of fire every time. In general, detectors may not always warn about fires caused by carelessness and safety hazards like smoking in bed, violent explosions, escaping gas, improper storage of flammable materials, overloaded electrical circuits, children playing with matches, or arson. Depending on the nature of the fire, and/or location of the smoke detectors, the detector, even if it operates as anticipated, may not provide sufficient warning to allow all occupants to escape in time to prevent injury or death.
- Signals sent by wireless transmitters may be blocked or reflected by metal before they reach the alarm receiver. Even if the signal path has been recently checked during a weekly test, blockage can occur if a metal object is moved into the path.
- Wireless transmitters (used in some systems) are designed to provide long battery life under normal operating conditions. Longevity of batteries may be as much as 4 to 7 years, depending on the environment, usage, and the specific wireless device being used. External factors such as humidity, high or low temperatures, as well as large swings in temperature, may all reduce the actual battery life in a given installation. This wireless system, however, can identify a true low battery situation, thus allowing time to arrange a change of battery to maintain protection for that given point within the system.
- Installing an alarm system may make the owner eligible for a lower insurance rate, but an alarm system is not a substitute for insurance. Homeowner, property owners and renters should continue to act prudently in protecting themselves and continue to insure their lives and property.
- A user may not be able to reach a panic or emergency button quickly enough.
- Passive Infrared Motion Detectors can only detect intrusion within the designed ranges as diagrammed in their installation manual. Passive Infrared Detectors do not provide volumetric area protection. They do create multiple beams of protection, and intrusion can only be detected in unobstructed areas covered by those beams. They cannot detect motion or intrusion that takes place behind walls, ceilings, floors, closed doors, glass partitions, glass doors, or windows. Mechanical tampering, masking, painting or spraying of any material on the mirrors, windows or any part of the optical system can reduce their detection ability. Passive Infrared Detectors sense changes in temperature; however, as the ambient temperature of the protected area approaches the temperature range of 32 to 40C (90 to 105F), the detection performance can decrease.
- Alarm warning devices such as sirens, bells or horns may not alert people or wake up sleepers if they are located on the other side of closed or partly open doors. If warning devices are located on a different level of the residence from the bedrooms, they are less likely to waken or alert people inside the bedrooms. Even persons who are awake may not hear the warning if the alarm is muffled by noise from a stereo, radio, air conditioner or other appliance, or by passing traffic. Finally, alarm warning devices, however loud, may not warn hearing-impaired people.
- This equipment, like other electrical devices, is subject to component failure. Even though this equipment is designed to last as long as 20 years, the electronic components could fail at any time.
- The most common cause of an alarm system not functioning when an intrusion or fire occurs is inadequate maintenance. **This alarm system should be tested weekly to make sure all sensors and transmitters are working properly.**

ALL RIGHTS RESERVED

No part of this publication may be reproduced, stored in a retrieval system, or transmitted in any form or by any means, electronic, mechanical, photocopying, recording, or otherwise without the prior written permission of the manufacturer. The material in this publication is for information purposes and subject to change without notice. The manufacturer assumes no responsibility for any errors which may appear in this publication.

Use of this control for fire detection and/or annunciation may not be permitted by certain states, counties, municipalities or local jurisdiction. It is the responsibility of the installing alarm company to check with the local A.H.J. (Authority Having Jurisdiction) or State Fire Marshal's office prior to using this control for fire detection.

Table of Contents

Specifications, Features, and Benefits	5
Wiring & Hookup Diagram	6
Section 1 - Installation and Wiring	8
1.1 Planning the Installation	8
1.2 Parts Diagram & Descriptions	8
1.3 Mounting and Wiring Preparation	8
1.4 Control Wiring	9
Data Bus E.O.L. Termination - VERY IMPORTANT!	12
Section 2 - Operating the System	14
2.1 Introduction	14
2.2 Powering Up (One Keypad)	14
2.3 User Codes and Authorities	14
2.4 Installer Program Code and Authorities	14
2.5 Keypad Overview	15
Keypad Menus	16
Multi-area (Partition) Operation	20
Section 3 - Programming The Control	21
3.1 Introduction	21
3.2 Local Keypad Programming	21
3.3 Local or Remote Computer Programming (Ness-RP) and Anti-Takeover	21
3.4 Area Partitioning	21
3.5 Communicator Setup Checklist	22
3.6 Entering Installer Level Programming	22
Menu 01 - Bus Module Enrollment	24
Menu 02 - User Code Options	25
Menu 03 - Area Definitions	26
Menu 04 - Keypad Definitions	28
Menu 05 - Zone Definitions	30
Menu 06 - Alarm Duration Timers	33
Menu 07 - Global System Definitions	34
Menu 08 - Telephone Account Setup	38
Menu 09 - Area Reporting Codes	40
Menu 10 - Zone Reporting Codes	42
Menu 11 - Keypad F-Key Reporting Codes	43
Menu 12 - Sys Report Code Options & Codes	44
Menu 13 - User Report Codes	46
Menu 14 - Wireless Definitions - (<i>For future product release</i>)	47
Section 4 - PC Programming and Automation Capabilities	49
4.1 NESS-RP Software	49
4.2 Update/Verify Firmware in the Control and Peripherals	50
4.3 Automation Rules and Attributes	51
Appendix A - Event Codes	58
Appendix B - Telephone Remote Control	60
Appendix C - Voice Message Vocabulary *RP only *	62
Appendix D - Two Way "Listen-in/Talk" Interface (optional)	64
Appendix E - SIA CP-01 Compliance	65
Appendix F - Regulatory Agency Statements	66
Appendix G - Additional Keypad Information	68
Index	71

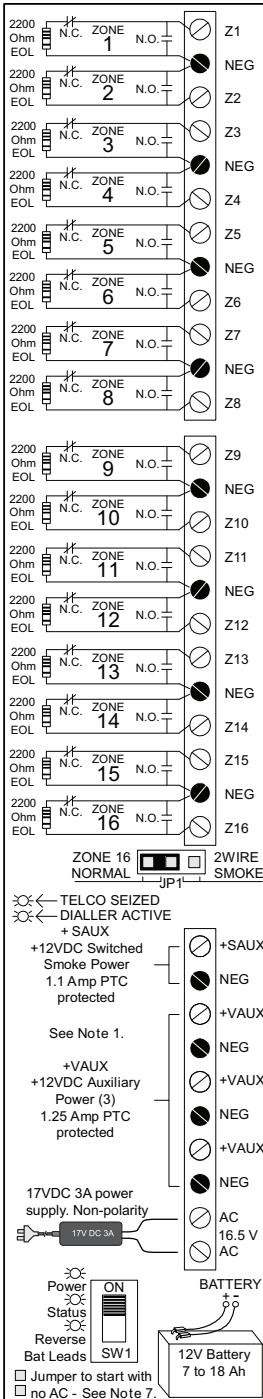

Ness M1

Cross Platform Control™
16 Zones expandable to 208



www.ness.com.au



NOTE 1. Maximum COMBINED continuous current drain from terminals +SAUX, +VAUX, +VKP, OUT2 and J16 is 1.5A. Under alarm the combined outputs should not exceed 2.5A.

NOTE 2. OUT 1 is for speakers 4 to 8 Ohms. If using more than 2 speakers, use series/parallel wiring to avoid going below a 4 ohm total load.

NOTE 3. OUT 2 may be set for speaker OR voltage. Speaker Mode is set by default. In Speaker Mode avoid going below 4 ohms total load. In Voltage Mode (switched to ground, 1A max.) use a 12V siren or screamer. OUT 2 is supervised against open circuit (in both Speaker and Voltage modes). If not used, install a 2.2k Ohm resistor across the terminals to avoid Output 2 Trouble condition.

NOTE 4. OUT 3 is a NO/NC dry contact relay rated 5A.

NOTE 5. OUT 7 to 16 are +12V switched POSITIVE VOLTAGE outputs rated at 50mA max.

NOTE 6. Do not connect any neg terminal to earth ground.

NOTE 7. If AC fails, low battery disconnect shuts down the control at 10.2 volts. To start the control with a good battery and no AC, short the silver pads momentarily. Replace the battery every 3-5 years and test it regularly with the NESS-BLT Battery Life Tester.

NOTICE: ADSL broadband can interfere with the operation of your alarm dialler. It is recommended that a quality ADSL filter be installed as per the filter's installation guidelines. Use Ness ADSL Filters 100-044 or 100-045.

Testing of this system should be performed regularly. Control panel specifications are subject to change without notice. Figures not to scale.

Document Part No. 440-426

Serial number located below on base.

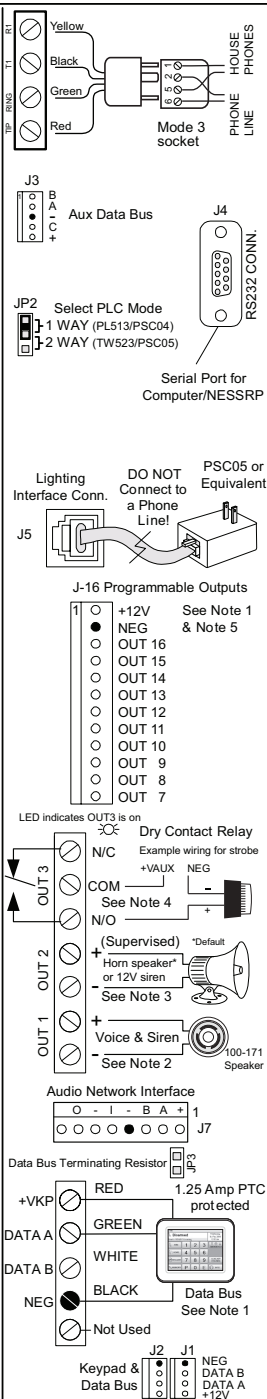

Features and Benefits

General:

- Large zone capacity: 16 on-board zones expandable to 208
- Wireless capability: Up to 48 zones
- Two Way Listen-in interface
- Flash Memory - Allows field updates to firmware electronically
- RS-232 serial port to interface PCs and peripheral devices
- Time/Date stamped 512 event history log
- Menu driven, text keypad programming - no manual required!
- Voice announcement of alarms, zone descs, status, etc.
 - 500+ Word/Phrase Vocabulary
 - Link up to 6 words/phrases per announcement
 - 10 custom recordable words/phrases
- 13 On-Board Outputs: 1 voice driver/siren, 1 siren driver/voltage, 1 form "C" Relay, and 10 low current (50 mA) voltage outputs
- Supports 4 wire (any zone) and 2 wire (zone 16) smoke detectors
- Includes Fire alarm verification routine
- Can be partitioned into 8 areas and account numbers
- User Codes: 99 (4 or 6 digit) with assignable authority levels
- Arm levels: Away, Stay, Stay Instant, Nite, Nite Instant, Vacation
- Plug-in terminal blocks make service and pre-wires a snap!
- Hardware "watchdog" and nonvolatile EEPROM memory
- Supervised phone line, alarm output, and aux. overcurrent

Communications

- True V.22 bis Modem for fast reliable upload/download
- Optional Ethernet port for reporting, operation, programming
- Built-in Phone Remote Control makes any phone a keypad
- Integrated Voice Dialer uses vocabulary or custom words
- Communicator formats: SIA, Contact ID, 4 + 2, and Pager
- Installer telephone (buttset) test feature
- Ness-RP PC programming software with conflict resolution to easily highlight differences between control and PC
 - Dial-up, ethernet, RS-232 port, or local house phone jack
 - Automatic answering machine bypass

Keypad options

Keypad

- Backlit, Large Character LCD Display, 16 x 2 lines (101-256 KP2, 101-255 KP3)
- Colour LCD touch screen (101-502 M1 Navigator)
- Optional Plug-in Prox Access reader (26 bit Weigand format)
- Menu navigation keys and programmable function keys
- Plug-in connector, only 4 wires to the control
- 1 Zone input and 1 Output Programmable per Keypad
- Programmable display of time, date, & temperature
- Displays system diagnostics and settings.
- Maximum Keypads allowed: 16

Automation&Integration

- Create lifestyle enhancing comfort, convenience, and security
- Powerful "Whenever/And/Then" RULES Programming allows almost any imaginable operation. No need to chain rules together. Any single "Whenever" event can have one or more ANDs and THENs (conditions and commands).
- Rules utilize easy to understand text based references
- Control lighting using RS-232 serial or 2-way Power Line Control (PLC) ports including On, Off, Dim, All On, All Off commands
 - Transmit and receive custom serial ASCII strings
 - Read Temperature Sensors - Communicate with Thermostats
 - Turn on Tasks, Lights, Outputs via Keypad or Telephone Remote
 - Sunset/Sunrise calculation and activation built-in
- Power Supply
 - Heavy duty - 2.5 Amp power supply w/ 1.5 Amp continuous
 - Dynamic battery test
 - Master power switch and Low battery disconnect
 - PTC (fuseless) resettable overload protection
- Multiple auxiliary power terminals

Wiring & Hookup Diagram

(Left Side Terminals)

This unit provides Residential fire alarm service when installed according to ANSI/NFPA 72-1993. This unit provides Grade A Residential Burglar alarm service. In conjunction with the enclosure, this unit also provides the following Commercial Burglar alarm service: Grade A Local, Police Connect with Basic Line Security, and Grades B & C Central Station. Transmission of the fire alarm signal to a fire alarm headquarters or central station shall be permitted only with the approval of the authority having jurisdiction. The burglar alarm signal shall not be transmitted to a police emergency number, equipment is to be installed in accordance with NFPA (985.55.1.P)

All circuits are current limited except telephone line and Battery leads.

Testing of this system should be performed regularly. Control panel specifications are subject to change without notice.

2200 (2k2) Ohm EOL Resistors are Ness part # 605-222

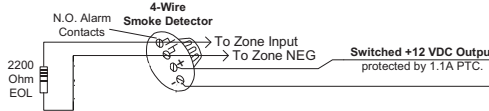
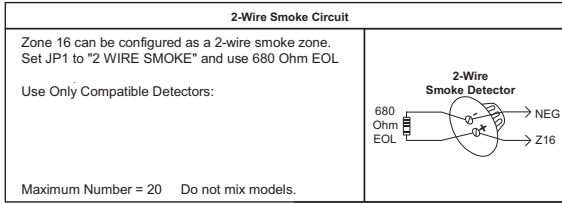
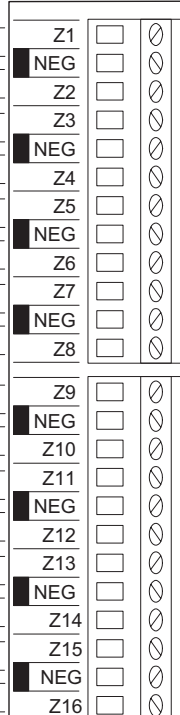
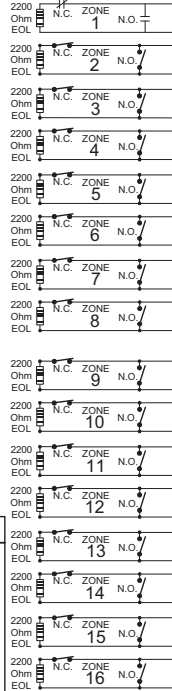

Auxiliary +12VDC Power Outputs protected by 1.25A PTC NOTE: Maximum continuous current drain from +VAUX, +VKP and J16 combined must not exceed 900 mA or 2.5 Amps in alarm.

UL Listed Class II Transformer
DO NOT CONNECT TO A SWITCHED OUTLET
16.5VAC, 45VA

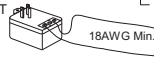

LED Indicators	Normal State	Descriptions
TELCO SEIZED	OFF	Phone line is good and house phones are connected. If ON constantly, the phone line may be bad. During remote mode this LED will be ON since the house phones are then disconnected from the outside line & are being powered from control.
DIALER ACTIVE	OFF	Dialer/Modem is idle. If ON, Dialer/Modem is in use (communicating).
Power	ON	AC Voltage is present and power switch is turned ON. If OFF, check AC power.
Status	Regular 1 sec. Blink	1 blink with equal On and Off times is Normal. 2 fast blinks = Control running on bootloader only. 4 fast blinks = Control is re-initializing it's EEPROM memory after a firmware flash. 5 fast blinks = Memory/Operation overflow
Battery Reversed	OFF	Battery is connected correctly. If ON, check battery lead connections.

Control requires AC power to start. However, for testing purposes it can be started from battery ONLY by momentarily shorting these two pads.

Master Power Switch (SW1), disconnects AC and Battery power from control

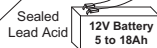
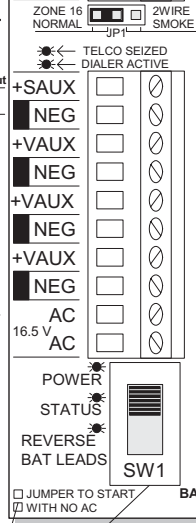

Test battery regularly with BLT Battery Life Tester. Replace every 3-5 years

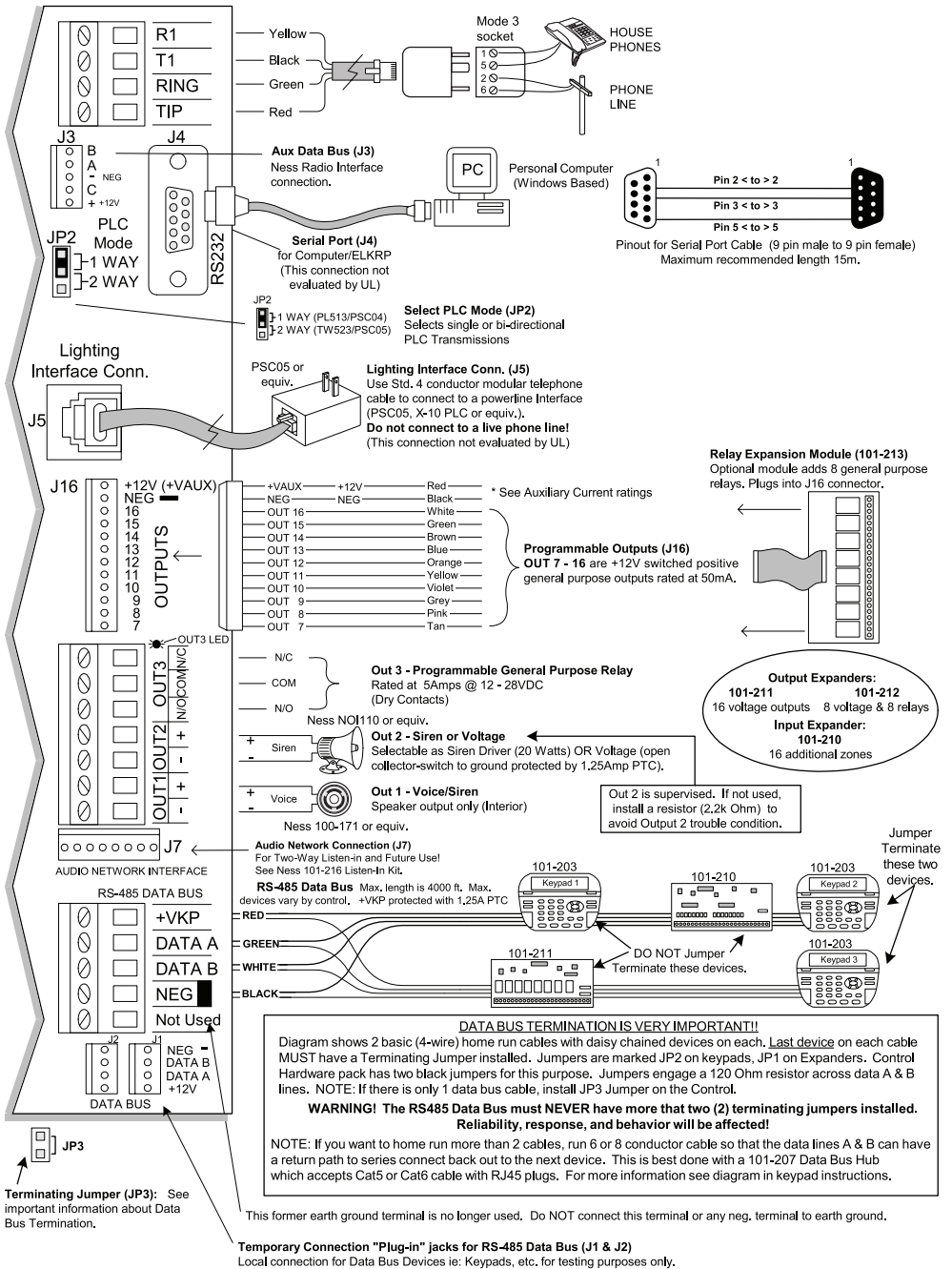

Section 1 - Installation and Wiring

1.1 Planning the Installation

The first step in any multi-zone security system installation is planning the job.

1. Read this entire manual to familiarize yourself with all system features and procedures before actually beginning the installation. Read all the information regarding Underwriters Laboratories (UL) and NFPA requirements.
2. Perform a physical survey of the installation site. Use the diagrams below as a guide in planning the installation.
3. Discuss the installation requirements and applications with the customer.
4. Compare the installation requirements and applications with the factory default settings to determine what customized programming is needed to meet the specific installation requirements.
5. Bench test the system prior to installation.

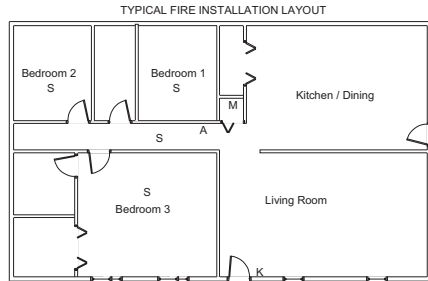
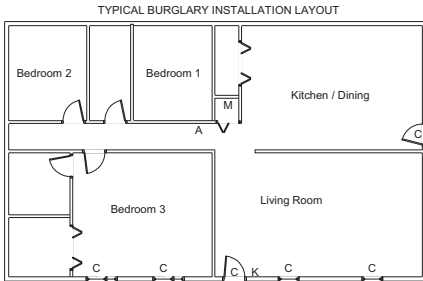

All perimeter openings below 18" should be provided with protection.

A Smoke Detector shall be located in each sleeping area and between the sleeping areas and the main living area.

Early warning fire detection is best achieved by the installation of fire detection equipment in the location shown above.

In homes basements or multiple levels at least one smoke detector shall be on each level.

Legend
M - Main Control
A - Audible Alarm
S - Smoke Detector
C - Contact
K - Keypad

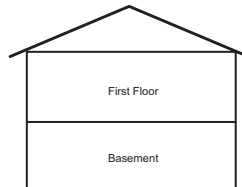

1.2 Parts Diagram & Descriptions

See Wiring & Hookup Diagram on pages 6 & 7.

1.3 Mounting and Wiring Preparation

Control Mounting

Remove all packing material and compare the system components with those in the figure above to familiarize yourself with the part names. Mount the control in a secure, dry location where the ambient temperature inside the control box can remain at 0' to +49' C (32' to 120'F). Choose a location that allows easy wiring to an unswitched power outlet and to a grounding conductor for the control. A central location makes running system wiring easier. Remove control box knockouts that best suit your wiring needs. Mount the control using the upper center slotted hole to level. Install and connect all necessary wiring for the power transformer, detection loops, keypads and siren outputs.

Keypad Mounting and Wiring

Ideal keypad height is 1.2 - 1.5 Meters above the floor. Select a location with an ambient temperature range between 0° and +49° C (32° and 120° F). Avoid direct sunlight if possible. Fasten mounting plate to electrical box (or directly to wall) using flat head screws to prevent shorts to the back of the circuit board. Keypads have a removable wiring plug for connecting to the M1 4-wire data bus. CAT5 or CAT6 eight (8) conductor cable is recommended for all Data Bus cables. The extra wires provide data return paths. Splice the Black, Red, White, and Green wires from the removable wiring plug to the Data Bus cable. Plug the connector into the back of the keypad. Tuck wires neatly into back plate and install Keypad on mounting plate. Each keypad has connections for an optional programmable output and a programmable zone input.

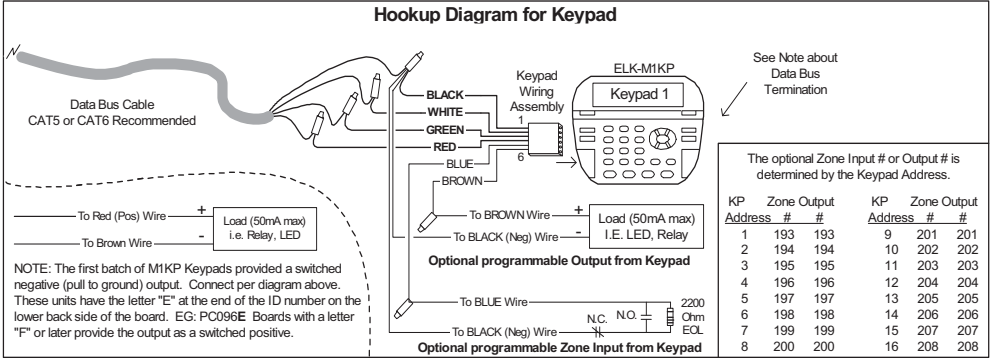

NOTE: Refer to the section titled Data Bus E.O.L. Termination for important information about how to handle multiple homerun cables. NEVER SPLICE OR CONNECT WIRE WITH CONTROL POWER ON. Minimum cabling should be four conductor 22 or 24 gauge. Maximum resistance per wire is 25 Ohms. Device placement beyond 300 mts is not recommended.

1.4 Control Wiring

Zones 1 Thru 16

The zone input terminals on the control board are labeled Z1, Z2, thru Z16. There are 8 common negative terminals mixed between every two zones with each negative to be shared by those two zones. Through programming each zone may be configured for standard EOL supervised (end-of-line resistor) function, as well as normally closed or normally open with no resistor required. By default each zone requires a 2,200 Ohm EOL supervision resistor at the furthest most remote end of the

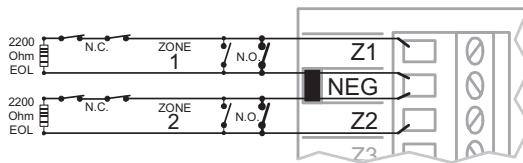

detection device wiring. A combination of N/C (normally closed) and/or N/O (normally open) devices may be connected to an EOL supervised zone.

Tip: The condition of any zone can be checked using a voltage meter across the zone and com terminals. A non-violated zone should measure approximately 7.0 Volts DC. If the circuit is violated in an open condition, the voltage should rise to 13.8 VDC. If the circuit is shorted across the EOL resistor, the voltage should be 0 VDC. One of the Keypad Menus also allows zone voltage to be viewed on the LCD screen. See Keypad Menus, "86-System Diagnostics" on [page 19].

1. Connect all alarm sensors to the zone wiring per the instructions provided by the sensor manufacturer and wiring diagram on pages 6 & 7.
2. Connect each zone wire to the appropriate terminal. Each zone has an input terminal and a common (negative) return. **NOTE:** A negative terminal is shared by every two zones and all negatives are common to each other.

Two-Wire Smoke Zones (Zone 16)

To enable the use of two-wire smoke detectors on Zone 16, move Jumper JP1 (located just below Zone 16 terminals) to the right side so that the two right hand pins are covered. Go to the installer programming mode, Menu 05 - Zone Definitions, and program Zone 16 as a Fire zone (Def=10). Step to the next location and program Wire Type=6. **NOTE Use only compatible two-wire detectors. When jumper JP1 is set for two-wire operation, a 680 Ohm EOL resistor (furnished in the hardware pack) must be used instead of the 2,200 Ohm. Maximum wire resistance must not exceed 60 Ohms.**

Switched Power Connection (+SAUX)

Four-wire smoke detector and other devices that require a temporary power disruption in order to reset or unlatch from the alarm state (i.e. smoke detectors, etc.) should be connected to the +SAUX 12 Volt DC switched power terminal. When a smoke reset is performed, the operating voltage to these devices is momentarily interrupted.

Auxiliary Power Connections (+VAUX)

Motion detectors, glass breaks, etc. and other devices requiring unswitched 24-hour power should be connected to one of the auxiliary terminals, +VAUX. All negative terminals on the terminal strip are at the same reference and may be used whenever a common (circuit ground) negative is required. Use caution when wiring the control to distribute the load devices among the supply and the negative terminals evenly. **NOTE: Circuit ground refers to any negative terminal connection on this control. This does not refer to the earth ground terminal or to the common terminals of Relay Output 3. These terminals are not at the same voltage potential and should not be wired so that they are electrically connected to a negative.**

PTC (Positive Temperature Coefficient) Circuit Breakers

The +VAUX Auxiliary power and J16 power output terminals are protected against shorts and overloads by a 1.25A PTC. A PTC is a solid state, auto-restoring type of circuit breaker. The +SAUX Switched (Smoke) power output is protected by a 1.1A PTC. The +VKP Keypad power output is protected by a 1.25A PTC. Output 2 is protected by a 1.25A PTC. **NOTE: Sometimes it may be necessary to remove power (unplug the outputs) for approx. 20 seconds after a short, to allow the PTC to reset. Even if the short is no longer present, the remaining residual current draw may be so high that the PTC cannot determine that the short is gone. If the PTC re-trips, check the field wiring and repair.**

Transformer Primary Power Input (AC)

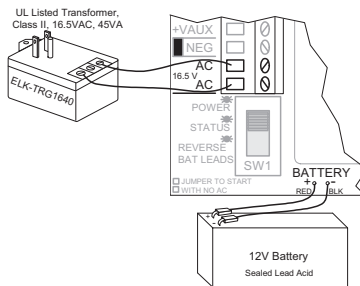

The control is powered by a 16.5 VAC, 40VA min., Class II (power limited) transformer (Ness part # 840-041). The specified sized and rated transformer must be used to operate this control. The transformer must be connected to a 120 VAC, 24-hour outlet not controlled by a switch other than an approved overcurrent protection device.

Connect the transformer to the AC Terminals using 16 to 18 gauge minimum wire. Do not exceed 15 meters between the transformer and the control or run the AC power in a multiconductor with other system circuits. Leave the transformer unplugged as well as the standby battery until all other connections have been made.

Standby Battery Connection

Connect the BLACK wire to the Neg (-) terminal on the battery, the connect the RED wire to the Pos (+) terminal on the battery. The control is designed to operate with and recharge a 12 volt, sealed lead acid battery from 7Ah up to 18 Ah for backup of the primary power supply. The control maintains a float charge for the battery of 13.8 VDC at 100 mA. This is in addition to the continuous output of 1.5 Amps that the power supply maintains (see maximum current drains for UL Listed Systems).

CAUTION: Do not reverse the battery leads! The control has special circuitry which helps protect it from battery reversal damage for short durations. However, prolonged reversal of the battery leads may cause permanent damage. A reverse battery warning LED is located to the left of the power On/Off switch. If this light is ON, turn the power off immediately and correct the battery lead connections.

AC Failure, Low Battery, and Automatic Low Voltage Shutdown

During an AC power failure the battery automatically takes over and AC Fail trouble annunciates at the keypad. The communicator can be programmed to report AC Fail to the Central Station after a time delay (see Menu 12, System Option 01).

If the battery voltage falls below 11.2 VDC a Low Battery Trouble condition will occur. The communicator can be programmed to report Low Battery to the Central Station. The battery will continue to run the control until its voltage reaches 10.5 VDC, at which time the control will disconnect and shut down to prevent a false alarm and damage to the battery. The AC Fail trouble display will clear if the AC restores. However, the Low Battery Trouble requires a manual or automatic battery load test before it will clear. An automatic battery load test is performed every 24 hours. See Section 2.2 for powering up the control.

Telephone Line Connection (R1,T1,T,R)

The telephone interface is connected by the use of an approved Mode 3 socket. This device allows the subscriber to disconnect the control/communicator from the public switched telephone network in the event of a malfunction. The control is equipped with line seizure so that the premises telephone service is interrupted during communication to the central station. Connection to the approved socket is done with a Ness Dialler cord (Part # 450 -200) which connects the control terminals to the mode 3 socket.

Outputs

There are 13 outputs on the main board. Outputs may be expanded utilizing output expander boards connected to the RS-485 4-wire Keypad data bus. Outputs 1 & 2 trip when any alarm is activated. All others must be enabled through the RP Rules Programming and can be triggered by multiple conditions "events". Do not exceed the current limits on voltage only outputs.

Output 1 is driven by an Audio Amplifier. It is designed to handle standard 8 ohm alarm speakers (never go below a total connected load of 2 Ohms) for inside or outside use. This output is the source for voice announcements such as: Zone 1 not ready, System Armed, Alarm Activated, etc., as well as alarm siren sounds. The initial start volume and the final volume can be adjusted in programming to suit the application.

Output 2 is a traditional Alarm output. It is factory set to produce alarm siren sounds into standard 8 Ohm speakers (never go below a total connected load of 4 Ohms). It can be alternately programmed to produce voltage only (12VDC) for driving self-contained sirens or siren driver boards

Output 3 is a Single Pole Double Throw Relay with form "C" contacts (Com, N/O, and N/C).

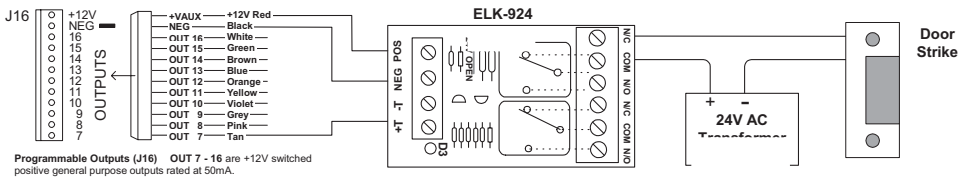

Using Output 7 (low current) with a sensitive relay to switch 24V AC to a Door Strike

Outputs 7, 8, 9, 10, 11, 12, 13, 14, 15, and 16 are low current, positive (+) voltage only, for driving LEDs, relays, etc. **Outputs 4, 5, and 6 ARE NOT available from the main board.** They can only be accessed with a data bus Output expander set to address 1. This expander will replicate all the main board outputs, including outputs 4, 5, and 6.

Earth Grounding

Tests and studies have determined that the best results against lightning and transients are obtained by isolating the control from ground. Do NOT connect any of the M1 terminals, especially the Neg. terminals to earth ground. Early production M1 circuit boards had a terminal marked "earth ground". This terminal is no longer used on circuit board revision 1 or later. However, ancillary devices such as the ELK-950 Surge Protector on the incoming Telephone circuit are still recommended.

Keypad & Expanders on the RS-485 Data Bus (+VKP, Data A, Data B, Neg)

Keypads and data bus expander devices connect to the four terminals marked +VKP, Data A, Data B, and Neg. The keypad plug-in wire harness color code is: Red +VKP, Green Data A, White Data B, and Black (-) Neg. The +VKP power terminal is protected by an auto reset PTC device. In the event of a short circuit or malfunction, power will be removed from all devices until the problem is resolved. Two (2) quick connect header pin plugs (J1 and J2) along the bottom of the board may be used for temporary purposes I.E. bench testing using a four conductor ribbon cable. Do not use for permanent connections.

Data Bus E.O.L. Termination - VERY IMPORTANT!

The M1 features a true RS-485 "differential" data bus operating at 38,400 baud (bits per second). This is a relatively high speed by industry standards and was designed to ensure fast, accurate communications. As a result of this high speed, data bus terminating resistors (120 Ohm resistors) are recommended in order to eliminate the possibility of reflection errors caused by varying cable lengths, especially with multiple home run (star topology) cables.

Every M1 data bus device; keypad, zone, output expander, etc. and the control board has a built-in bus terminating resistor (120 Ohm). Each terminating resistor is installed (activated) via a 2 pin header/jumper using a small black shorting cap. **The 2 pin header is marked JP1 on keypads and expanders (except KP1 keypad, marked JP2).** From the factory, no terminating resistors are installed (activated). The control hardware pack includes two of the small black shorting caps. When a shorting cap is placed on the two pins, it installs (activates) the built-in 120 Ohm terminating resistor across Data Lines A & B.

WARNING! The RS-485 Data Bus must NEVER have more than 2 terminating resistors header/jumpers installed. Reliability and response will be negatively affected. See diagrams on opposite page.

Ideally, there should be no more than two home run data bus cables, with devices daisy chain connected along the two cables and a terminating resistor (header/jumper) installed on the last device of each cable. However, if you prefer to home run everything (3 or more), we highly recommend using 6 or 8 conductor cabling (CAT5 or CAT6 cable is ideal). At each device, splice data wires A & B to 2 of the extra conductors so they return back to the control as A1 & B1. At the control, splice the returning data wires A1 & B1 in series to data wires A & B going back out to the next device. Remember to install a terminating header/jumper on the last wired device. Electrically the data wires are now in one long series circuit. Connect the POS (+) and Neg (-) power wires of each device directly to the M1's +VKP and Neg terminals. **DO NOT SERIES THE POWER WIRES** as this will cause unnecessary voltage loss.

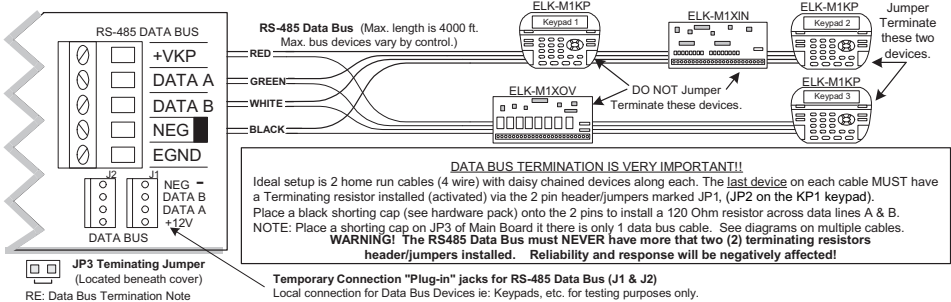

Diagram for Daisy Chain Connection of Data Bus Devices Using Two (2) Home Run Cables

If home running 3 or more cables, use 6 conductor cables. At the device, make a three way splice of the data A wire, device A wire or terminal, and a return data A1 wire (using one of the extra wires). Do the same for the data B wire. At the control, make a two way splice of the data A1 return wire (series connection) to the outgoing data A wire of the next cable. Repeat for the data B wire. Terminate at the last device and the control JP3 ONLY!

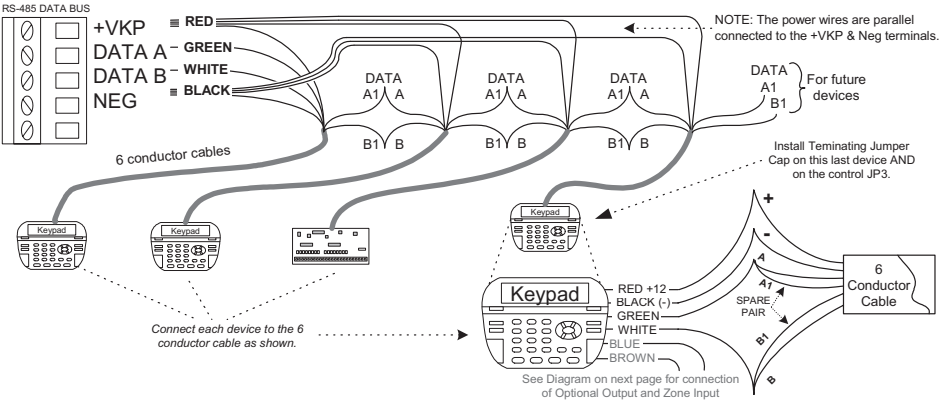
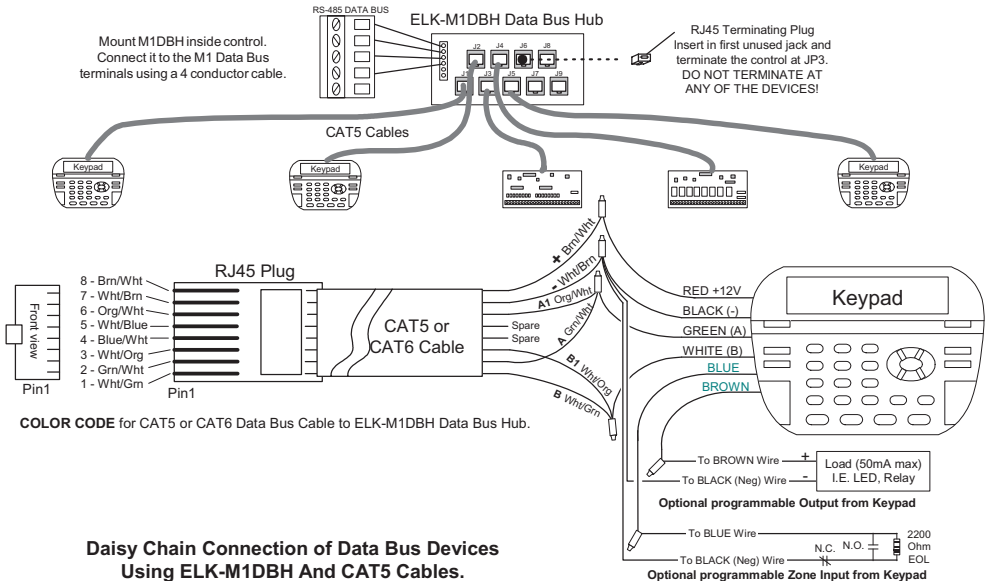

Diagram for Daisy Chain Connection of Data Bus Devices Using 3 or More Home Run Cables.

The ideal way to connect multiple home run cables is with an ELK-M1DBH Data Bus Hub. It accepts CAT5 or CAT6 cable with RJ45 plugs on the ends. It does all the work of series connecting the DATA lines A & B. Terminate at the hub using the included RJ45 Terminating Plug in the first unused jack.



Setting the Data Bus Address and Enrolling Device(s) into the System

Keypads and expander devices communicate with the M1 over the RS-485 4-wire data bus. Each device must have a unique address setting (from 1 to 16) within its device type. Keypads are device TYPE 1, input (zone) expanders TYPE 2, output expanders TYPE 3, etc. The purpose of device types is so that the address numbers can be re-used in each different device type. It is OK to have a Keypad, a Zone Expander, and a Output Expander all set to address 2 and on the same data bus since each device is a different device type. **It is NOT OK to have duplications of addresses within the same device type. I.E. Multiple keypads on the same control cannot be set to 'like' addresses.**

ADDRESS: From the factory all keypads are set to address 1. Valid keypad addresses are 1 to 4 for the ELK-M1, or 1 to 16 for the ELK-M1G. The first keypad on the system (Keypad 1) is automatically enrolled upon power up. Each additional keypad must be assigned a unique address and then manually enrolled from "Menu 1 - Bus Module Enrollment". (See M1 Instruction Manual, Menu 01, for complete instructions on Bus Module Enrollment)

1. Press and hold the "*" key, followed by the F5 key . HOLD BOTH keys pressed for 5-10 seconds or until the LCD displays:

Exit when done. F1 Set Addr. (This is Keypad setup mode)

NOTE: This mode may also be accessed by removing power from the keypad (unplugging the data bus cable) and then applying power while holding any key pressed.

2. Press the F1 key to display the current address setting.
3. Set the desired address by entering a number from 1 to X.
4. Press the Exit key when done.

ENROLLING:

1. Press the ELK key, then press 9 (or scroll up) to display 9 - Installation Programming. Press the RIGHT arrow key to select this menu. The Installer Program Code (PIN) must be entered to access this menu.
2. Enter the Installer Program Code. (See M1 Manual for the default Code)
3. The first Installer Programming menu displayed will be "Bus Module Enrollment"
4. Press the RIGHT arrow key to select this menu. "Enrolling Bus Modules" will display
5. The M1 transmit an enrollment message to all data bus devices, following by a display showing the total Bus Modules that are enrolled. To view the enrolled devices and/or remove a device press the RIGHT arrow key next to the word Edit.
6. Press the * or Exit keys to exit Installer Programming.

Auth. Required
Enter Valid Pin

01-Bus Module
Enrollment

XX Bus Modules
Enrolled, Edit x

Section 2 - Operating the System

2.1 Introduction

For best operation during bench testing, all zones should be terminated with end of line resistors and the correct transformer and battery should be connected to the unit. The control comes with factory default programming, allowing it to be bench tested prior to installation. The factory default code for user 1 is 3456. This code is authorized to operate all user related features of the system. The control is designed to accommodate the grouping of specific zones into partitions called areas and by default, all zones are assigned to area #1. This is the most common mode in which the system operates. This section of the manual gives an overview of powering up and basic keypad functioning.

2.2 Powering Up (One Keypad)

After all other connections have been made and checked thoroughly, the controls AC transformer and battery may be connected. The Master Power Switch located on the lower left corner can then be turned on which will complete the AC and battery connections into the control. Upon power up the control will perform self-diagnostics and auto-enroll the first keypad (Keypad Address #1). Any additional keypads or expanders must be manually enrolled using Installer Level Programming. See "Menu 01 - Bus Module Enrollment".

NOTE: It is very important to make certain that every keypad, input expander, output expander, or any other data bus device be assigned a unique data bus address within its type. See "MENU 01 - Bus Module Enrollment" for instructions on setting keypad and expander addresses.

System Startup on Battery Only

Ordinarily, the control will not startup without AC power. However, if AC power is not available (new construction sites, field testing, etc.) it is possible to start the control on battery ONLY! Locate the two silver pads on the lower left corner of the circuit board. Take a small blade screwdriver and short these two pads. This will temporarily bypass the AC sensing circuit and allow the control to startup. The On/Off power switch must be in the On position.

2.3 User Codes and Authorities

The control has 99 user passcodes plus one installer passcode. Each user code may be assigned specific authorities as to what it is allowed to do. The authorities are assigned from the Installer level programming, however the code numbers and user name is assigned from the keypad user menu 6 - Change User Codes. Only a Master authority level code or the Installer code is allowed to access keypad user menu 6. The User's Guide contains a description of panel operations accessible to the user codes. Control operations accessed by the installer passcode are slightly different.

The Factory Default Code for User Code 1 is: 3 4 5 6 (Master Code)

(If the six digit code option is enabled, User Code 1 default will then be: 1 2 3 4 5 6)

The user code may be used for functions in a specific area or system-wide. Some options may be performed at any time, even while the control is fully or partially armed. The menu system is designed to be next-step-oriented. After a brief explanation of the options, the user should be able to begin operating the system immediately. For purposes of discussion, the installer and the end consumer are both considered users, but have different capabilities.

2.4 Installer Program Code and Authorities

The installer code can access all the keypad user menus, including of course menu 9 - Installation Programming. The Installer code also has limited arm/disarm privileges. It may be used to arm any area and may be used to disarm any area, so long as that area was armed specifically by the installer code. The Installer code cannot disarm if an area was armed by any user code. The Installer code may be used to silence 24hr alarms or a Burglary alarm in an area that was armed by the installer or in an area that is not armed. The installer code may also be used to silence a trouble condition in a disarmed area. See User's Guide for a full description of arming and disarming procedures.

The Factory Default Installer Program Code is: 1 7 2 8 3 9

2.5 Keypad Overview

Ready Light - This light is ON when all burglar zones are secure and the system is OK for arming. If this light is OFF, one or more zones are violated (not secure). For maximum security, all zones should be secured before the system is armed.

If FLASHING, one or more force-armable zones are violated. Force arming temporarily excludes violated zone(s) from the system. However, if a force armed zone becomes secure while the system is armed, it will automatically restore to service. This is handy for a garage door. The system may be armed with the door up, but once the car is backed out and the door is closed, it will become secured.

Armed Light- This light will be ON when the system is armed. The mode of arm will be indicated by the LCD display and the Exit or Stay lighted pushbuttons. This light will be OFF when the system is disarmed.

Exit Key - This lighted key may be programmed for single or double press arming to the AWAY (not occupied) mode. If the Exit light is ON the system is armed and all perimeter sensors and interior motions are active. The Away key may be pressed during the exit delay time t to convert from Away mode to Away Vacation mode. The Away Vacation mode is primarily for use with the Whenever/And/Then Rules programming of Elk-RP to invoke long term energy savings.

Stay Key - This lighted key may be programmed for single or double press arming to the STAY (occupied) mode. If the Stay light is ON the system is armed and all interior zones are excluded (bypassed). Only perimeter doors and windows are active in the Stay mode. This key may also be programmed to change to other Stay modes such as: Stay Instant, Stay Night, and Stay Night Instant. Since interior zones are automatically excluded once the Stay mode is activated, the M1 allows this key to Stay arm even while one or more interior zones are violated, provided they are programmed for "force arming". The Stay Night mode re-activates any interior night zones. To prevent a false alarm the control will not allow change to the Stay Night mode when a interior night zone is violated unless it is programmed for "Force arm".



Chime Key - Chime produces an audible alert whenever certain doors, windows, or other selected zones are violated. There are four different selections: Tone only, Voice, Tone/Voice, and Off. In the programming mode this key also functions as an insert character key for text programming. The key light indicated when Chime is On.

Bypass Key - Pressing this key followed by a zone number and the bypass key again will exclude or bypass the selected zone. This key may also be used to delete a character during text programming. When the Bypass key is lit, one or more zones are bypassed.

*** Key** - This key serves as a clear or reset key. If an error is made while entering digits, pressing this key clears the error. Three presses is a master clear.

Key - This key is currently a duplicate of the Bypass key.

Numerical Keys - These keys are used for entry of passcodes, programming, etc. Keys 2 - 9 also have an assigned alpha character which are used for entering text.

Arrow Keys - The menu and arrow keys have powerful functionality used for both normal operation and programming. Pressing the Menu key displays relative information according to each application. The arrow keys allow scrolling through all available options. The user can activate or select the displayed option by pressing the right arrow key. Once an option has been selected, the user may be prompted for a passcode. Additional sub-menu options may appear to assist. The user may return to the status screen by pressing the * key.

Keypad Menus

READY TO ARM
9:00AM 08/01/03

The control offers extended Menu Options via the center navigation "ELK" key. Some menus may require a valid code to authorize. **The Factory Default Code for USER Code 1 is: 3 4 5 6** (1 2 3 4 5 6 if the six digit code option is enabled)

Access to menus 1 to 5 can be restricted via programming to only Users that have "User Code Option 8" set. Menus 6 & 8 required a Master or Installer Code. Menu 9 requires the Installer Code. Press ELK to begin, then press the UP or DOWN arrow key to select a menu. Enter a code if prompted. To select a menu press the RIGHT arrow key.

1-View/Control Automation Fncts

Allows viewing or controlling of the automation functions such as Tasks, Lighting, Outputs, Temperature Sensor, Keypad Temperature, and Thermostats. Press the RIGHT arrow key to select, then choose the desired function using the UP or DOWN arrow keys.

NOTE: The automation functions must be assigned and named using the NESS-RP software. In most cases they cannot do anything unless they have been written into one of the "Whenever/And/Then" automation rules.

1-Tasks

Tasks are like 1 button macros, performing multiple jobs with one push. To activate a task press the RIGHT arrow key and press UP or DOWN to scroll through the list of available tasks. To jump directly to a particular task, enter it's two digit number. Once the task is displayed, all it takes to activate it is to press the # key. A rule to use the "Water the Lawn" task might be: WHENEVER "Water the Lawn" IS ACTIVATED THEN TURN ON Valve 19 FOR 5 MINUTES, etc.

Water The Lawn
01: # Activates

2-Lighting

Lighting allows the individual control of lights and/or appliances which have been assigned through the Ness-RP software. Press the RIGHT arrow key to select Lighting, then press the UP or DOWN arrow keys to scroll through the list. If you know the three digit number, you may enter it to jump directly to that Lighting/Appliance. The current state of the unit will be displayed. Press the # key to toggle (change) the unit from on > off or from off > on.

Kitchen Lights
001:=Off, # to Chg

3-Outputs

Outputs might be relays or voltages used to actuate something like a motor, fan, pump, etc. Outputs can be turned on or turned off from this menu. Press the RIGHT arrow key to select Outputs, then press the UP or DOWN arrow keys to scroll through the list. If you know the three digit number, you may enter it to jump directly to that Output. The current state of the output will display. Press the # key to toggle (change) the output from on > off or from off > on.

Pump Motor Cntrl
001:=Off, # to Chg

4-Temperature Sensor

Remote "**Zone**" **Temperature Sensors** can be read from this menu. Press the RIGHT arrow key to select this menu, then press the UP or DOWN arrow keys to scroll through the list of available sensors. To jump directly to a particular sensor enter it's two digit number. The current temperature will be displayed. Press the * key to exit.

Outside
S01:=032 Degrees

5-Keypad Temperature

Keypad Temperature Sensors can be read from this menu. Press the RIGHT arrow key to select this menu, then press the UP or DOWN arrow keys to scroll through the list of available keypads. To jump directly to a particular keypad enter it's two digit number. The current temperature at the keypad will be displayed. Press the * key to exit.

Keypad 01
K01:=073 Degrees

6-Thermostat Temperature

Thermostats can be read from this menu. Press the RIGHT arrow key to select this menu, then press the UP or DOWN arrow keys to scroll through the list of available thermostats. To jump directly to a particular thermostat enter it's two digit number. The current temperature at the thermostat will be displayed. Press the * key to exit.

Hallway
T01:=072 Degrees

2-Reset

Used for resetting latched smoke detectors after a fire alarm activation..

Smoke Detectors

Press the RIGHT arrow key to actuate the Reset Smoke Detector feature. This causes the power to smoke detectors to be removed for 5 seconds. During this time all fire zones will be ignored to keep an accidental alarm from occurring.

5 Seconds Smoke
Output Reset

Continued on next page..

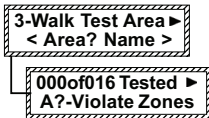

Menu 3 permits a local walk test of all zones assigned to this keypad's area. The siren(s) and communicator are disabled during a walk test. Press the RIGHT arrow key to begin a Walk Test. The keypad displays the total tested zones adjacent to the total number of zones involved. When a zone is activated, it's name is displayed across the bottom and can be audible if the Chime mode is on.

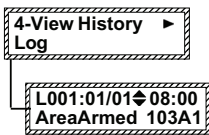

Allows viewing of the past 512 activities stored in the history log. Press the RIGHT arrow key to view the History Log. History activities include: Arm, Disarm, Alarm, Trouble, etc. The top line displays the Log number, Mth/Day, Time, and event description.

L001 is always the most recent event. Press the UP or DOWN arrow keys to move forward and back. Event 512 will be the oldest event. The bottom line displays the event description, the extended data (zone, user, etc.) and the area number (A1-A8).

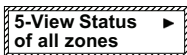

Allows viewing of the current status of all zones. Press the RIGHT arrow key to select. Press UP or DOWN to scroll through the zones or enter a three digit number to jump directly to a particular zone. I.E. for zone 16 enter 016. Press the * key to exit.

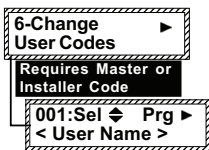

For changing a user code and/or name for codes which have been previously enabled by the Installer. Only a Master code OR the installer code can access this menu. Press the RIGHT arrow key to begin. Press UP or DOWN keys to locate a user, or enter 3 digits to jump. Press RIGHT arrow key to view the existing code. To change, enter the new code digits and listen for 3 beeps to confirm. To edit the name, press the RIGHT arrow key once, then press the DOWN arrow key. Enter the text using the letters on the keys. I.E. For "K" press the 5 key twice. Move RIGHT or LEFT with the arrow keys. Press Chime to insert a space. Press Bypass to erases a letter. The UP and DOWN arrow keys shift from upper to lower case letters. Press the ELK key to save and exit.



Allows an end user to change up to 20 settings incorporated into an automation rule. These settings can be: time of day, time duration (seconds), or a numeric value. Each custom setting has a reference number (CS) and a text description: I.E. CS01: Sprkl On 00:00 [Time] implying a time of day setting. Press the RIGHT arrow key to begin.

Press the UP or DOWN arrow keys to locate a setting, then press the RIGHT arrow key to select. Enter the new value and press the ELK key to save and exit.

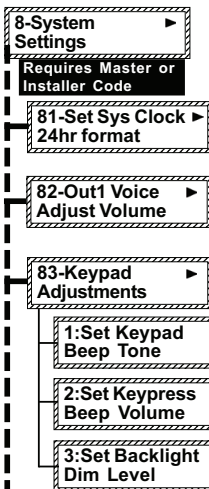

Menu 8 consists of 8 sub-menus used for advanced system settings. Press the right arrow key and enter a valid user code. Press the UP or DOWN arrow keys to select a sub-menu or enter the one digit number to jump directly to any sub-menu. I.E. enter 6 to jump to 86.

To set the system clock press the RIGHT arrow key, then press the UP or DOWN arrow key to select the day. Next, press the RIGHT arrow key to move to Date/Time setting. Enter two digits for month, date, year, hour, and min. To exit press the * key.

To set the volume for output 1 voice messages (non-alarm) press the RIGHT arrow key and set desired volume with the UP or DOWN keys. There are 8 settings (0-7). WARNING: PROTECT EARS! Each adjustment broadcasts a test message through Output 1. To exit press the * key.

To set keypad adjustments press the RIGHT arrow key. Then press the UP or DOWN keys to select one of the three options.

To set keypad beep tones press the RIGHT arrow key, then select the desired tone using the UP or DOWN keys. There are 9 settings (0-8). When done, exit by pressing the * key.

To set key-press beep volume press the RIGHT arrow key, then select the desired volume using the UP or DOWN keys. There are 7 volume levels (1-7) plus Off (0). To exit press the * key.

To set backlight dim level press the RIGHT arrow key, then select the desired level using the UP or DOWN keys. There are 9 backlight levels (1-9) plus Off (0). The keypad automatically dims to this setting after 30 seconds of no activity in order to save energy. To exit press the * key.

84-System Tests

To perform system tests press the right arrow key. Then press the up or down arrow keys to select one of the three tests.

1:Battery Test for 30 Seconds

The control's standby battery is load tested automatically every 24hrs. However, it can also be manually load tested anytime using this option. Press the right arrow key to start the test. The battery is placed under load for 30 seconds and the battery voltage and system current is displayed. If the battery falls below a set level, a Low Battery trouble will occur. If it's necessary to replace the battery, this test should be used to test and clear a Low Battery Trouble condition.

2:LCD Test

To test the keypad's LCD screen press the RIGHT arrow key. The entire screen should appear black indicating all pixels are working. To exit press the * key.

3:Communicator Manual Test

To manually test the communicator (dialer) press the RIGHT arrow key. Testing is done using the first phone number that is programmed to send a test code. If there is no phone number programmed to send a test code, the test will end. To exit this menu press the * key.

Send Test

Silently

There are two types of test, silent and monitored. To silently send a test press the right arrow key from this display. To hear the test using the inside speakers (OUT1) press the up or down arrow key to bring up the following display.

Send Test w/ speaker monitor

This unique feature permits you to hear or "monitor" a single communicator test using the inside speakers (OUT1) eliminating the need for a telephone "Butt" set. Simply press the right arrow key from this display to begin.

Turn Butt Set Monitor Mode On

Similar to above, this works for multiple communicator tests. Press the right arrow key to enable. Each communicator transmission will be monitored until mode is canceled. Press the star (*) key three times to cancel. Canceled automatically after 24hr daily battery test.

Clear Pending Dialer Reports

This special option allows any pending (not reported) dialer communications to be cleared or cancelled. Typically this will be used only for initial installation and testing.

NOTE: ALWAYS NOTIFY THE MONITORING STATION BEFORE TESTING THE DIALER! If the test should fail, a Comm Fail trouble will occur. To clear a Comm Fail the dialer must be able to complete a good communication.

85-Connect 'RP' Remote Program

To connect Ness's Remote Program PC software (RP) via the user assisted method, press the RIGHT arrow key and then select the connection mode with the UP or DOWN arrow keys.

1:Seize Line Attended Mode

1:Seize Line Attended Mode - 1) Allows RP connection to begin on an already established voice connection between the control phone line and the RP Computer. 2) Also useful for manually answering an incoming call from the RP Computer with programming Rings to Auto Answer.

2:Seize Line UnAttended Mode

2:Seize Line Unattended Mode - Pressing the RIGHT arrow key causes the control to dial the programmed RP telephone number. The RP Computer must be in the "wait for call" mode.

86-System Diagnostics

This is a collection of tools for diagnosing system problems. Press the RIGHT arrow key and enter a valid user code to begin. Press the UP or DOWN keys to select one of the four tools:

1:DataBusErrors T2A1 Retry 00000

This tool is useful for determining if data bus errors are accumulating. It displays the device type and number of retries accumulated since the last power-up.

2:Sys Volt/Curr 13.8V 0.440Amps

This tool displays the control's voltage and the average current being drawn from the power supply.

3:Zone=001 Volts Display Level

This tool allows the voltage on each zone to be displayed in real time. It changes as contacts or devices are violated. Press the RIGHT arrow key to begin.

Zn=001 Volt=07.2 L04.6 H09.0 A132

Use the UP or DOWN keys to scroll through each zone. The displayed information consists of: the present zone voltage, the L low and H high alarm thresholds, and the analog (A to D) equivalent of the zone voltage..

4:LastOnHook Tele Line V=57,+20%

This is a read only screen displaying the telephone line voltage during the last on-hook condition. It is an approximate measurement accurate to only +/-20%.

87-Custom
Message Record ▶

This option is used in conjunction with a house telephone (microphone) to record up to 10 custom voice messages. Each message occupies a 6 second block. Two or more consecutive blocks may be linked together for longer times. Total record time cannot exceed 60 seconds. These messages require the Ness-RP software, which utilize these messages together with the built-in 500+ word vocabulary to construct voice phrases for many uses, including the voice dialer. Press the RIGHT arrow key to begin custom message record.

VM01↕ 1 Block(s)
Record< Play>

Selects any one of the custom messages (VM01-VM10) for playback or recording. Press the UP or DOWN arrow keys to select. To play the selected message press the RIGHT arrow key. The message will play through Output 1 speakers. To record a new message press the LEFT arrow key. To exit press the * key.

6 Sec Blocks=01↕
Record< PlayAll>

This sets the number of consecutive 6 sec. record blocks. The default is 01 blocks which is normally long enough for most applications. However, to create a longer message press the RIGHT arrow key and enter the number 01 to 02, etc. NOTE: Creating longer messages reduces the total number of custom messages. This screen also allows all messages to be played "PlayAll" by pressing the RIGHT arrow key. When ready to record press the LEFT arrow key.

6 Sec Blocks=01↕
Rec< LiftPhone!

This is the prerecord screen. To begin recording: 1) lift the house phone (off hook), 2) press the LEFT arrow key, 3) start speaking. To stop recording press the "0" key. If stop is not pressed, recording will automatically end after 6 sec. (or the total number of blocks times 6 seconds).

NOTE: A local house phone is used as the microphone. Installer programming menu 07, option 1, must be set to a 1 in order for the local phone to be recognized by the control.

VM01↕ 1 Block(s)
Record< Play>

This will display as soon as recording has stopped. To play the new message press the RIGHT arrow key. To record the message again press the LEFT arrow key and follow the same procedures again. To exit press the * key.

Step by step summary of procedures for recording a custom message:

- 1) Verify that a house telephone is connected to the control's T1 and R1 terminals and that Installer menu 07, option 1 is set to a 1. This allows the control to recognize the telephone and allow it to be used as a microphone.
- 2) Go to the user menu 8-System Settings by pressing the ELK key and entering 8. Press the \times key and enter a valid user code. Press 87 to reach the custom message record screen.
- 3) Using the Up/Down arrow keys, select the voice message to record VM01 to VM10. There are 10 custom messages.
- 4) Press the 1 key and select the number of 6 second blocks for your message. Hint-rehearse and time the message, if it is greater than 6 seconds then increase the number of consecutive blocks as required.
- 5) Lift the telephone handset and press the 1 key to begin the recording. The recording will not start until the handset is off-hook and the 1 key is pressed.
- 6) Record your message by speaking into the handset. If the message is shorter than the amount of time selected then press 0 to stop recording. Otherwise, recording will stop when the number of blocks is reached.
- 7) Press the Right arrow key to play the message. The message will be heard through the telephone handset if it is still off-hook. Otherwise the message will be directed to the amplifier connected to output 1.

9-Installation
Programming (0) ▶

Requires
Installer
Code

From this menu you may press the RIGHT arrow to enter Installation Level Programming. If the Installer Programming Code has not already been entered it will be required at this time.

REFER TO PAGE 22 FOR PROGRAMMING INSTRUCTIONS

NOTE: The Remote Programming RP software can be used to lockout certain local program capabilities for "anti-takeover" purposes. The number in the lower right corner of this menu will indicate the level of lockout as follows:

(0) = No lockout,

(1)=Lockout Telephone number programming - view everything,

(2)=Lockout ALL programming - view everything,

(3)=Lockout ALL Programming and Viewing. This can only be set or removed from the Ness-RP Remote Programming Software.

Multi-area (Partition) Operation

0-Select Keypad
Alternate Area ▶

This menu allows the keypad to be mapped temporarily to any other area, allowing multi-area (partitioned) operation. The mapped area can be armed, disarmed, and otherwise controlled just as if the keypad were permanently assigned to that area. It may also be used to display a snapshot of all areas at once, showing the status of each area at once.

Auth. Required
Enter Valid Pin ▶

Press the **RIGHT arrow key** to select and display the following screen.

Enter a **valid user code**. The control does not allow (restricts) mapping or viewing of areas that are not authorized for the user code. The following screen will be displayed:

Select Area- 1 ▶
[Area Name]

MAPPING TO AN INDIVIDUAL AREA

Enter the **area number** to be mapped OR scroll UP and DOWN with the arrow keys.

READY TO Arm
[Area Name]

Pressing the **Exit or * key** will map the Keypad to the area shown. The keypad will now display the status, including LEDs and the LCD screen of the mapped area. For the next 1 minute it will be possible to arm, disarm, bypass, etc. the mapped area from this keypad. The 1 minute will be extended with each keypress. The keypad will return to its primary assigned area after 1 minute of no keypress activity.

Select Area- 1 ▶
[Area Name]

MAPPING TO A CONSOLIDATED DISPLAY OF ALL AREAS

Pressing the **RIGHT arrow key** will map the Keypad to a consolidated 'snapshot' display of all areas which the user code was authorized to operate. This display permits quick arming and disarming only. If a area is not ready to arm it will be necessary to map individually (see steps above) to that area to view the violated zone(s) and either secure or bypass them prior to arming.

Area# 12345678
Status= Xr r r r r r r

The example at left shows that the user code was authorized for all 8 areas, as indicated by a letter beneath each of the 8 area numbers. The letters show the status of each area. A lower case "r" means the area is Ready to Arm, a lower case "n" means Not Ready, a upper case "A" means Armed, and a upper case "X" means that area is the primary area assigned to the Keypad which cannot be operated from the consolidated display.

Area# 12345678
Status= Xr r - - - - -

The example at left shows that the user code was only authorized for areas 1, 2, and 3. The unauthorized area(s) have a "-" beneath them.

To change (toggle) the arm status of an area, press the number key representing the area number. **IMPORTANT:** The area status is not "real time". It is a snapshot taken when the **RIGHT arrow key** was pressed. If a zone has since become violated the area will still be displaying "r", however the letter will immediately change to "n" and the keypad will emit an error tone when an attempt is made to arm by pressing the area number.

NOTE: This is a new feature which became available with firmware release version 4.2.5. The firmware may be flash upgraded in older controls to add this capability.

Section 3 - Programming The Control

3.1 Introduction

The Security functionality of the M1 Control can be programmed either from an ELK-M1KP LCD Keypad OR from the NESS-RP PC Software. The keypad features a menu-driven "Text" based interface with simple Yes/No answers for most options. After just a short amount of experience the average installer will not even require an instruction manual to keypad program the control.

For the Automation functionality the NESS-RP PC Software is a requirement. The options and capabilities available for automation are so unique and powerful that it takes a PC to make use of all the benefits. The M1 features a powerful "Whenever/And/Then" RULES based programming that allows almost any imaginable operation.

3.2 Local Keypad Programming

There are two levels of operation for programming the control locally, user level and installer level.

- User level programming provides the ability to add, change, or delete user passcodes and names. It also allows custom automation settings to be viewed and changed. A master user code is required to access the user code and custom settings screens. User programming is explained in the User's Guide.

- Installer level programming allows total customizing of the Security operating features. Only the installer code may access this level. **If the installer code is lost or forgotten, it is impossible to program the control locally.** Anyone attempting installer level programming should be familiar with the contents of this publication prior to programming the control panel. If remote programming is used, it is possible to "lock out" or prevent takeover of a control by another installation company by selecting "Lockout Local Prog." This prevents the installer passcode from gaining access to programming via an LCD keypad. The installer passcode may still be used for the non-programming functions described in Chapter 2. Lockout Local Prog does not affect remote programming.

3.3 Local or Remote Computer Programming (NESS-RP) and Anti-Takeover

NESS-RP programming utilizes extensive error checking and security safeguards, including data encryption, password log-on, serial number, and dealer assigned RP access code. The serial # identifies the control to RP while the RP access code identifies the computer to the control prior to a programming session. RP loads the access code during the first connection. It cannot be viewed or changed from local keypad programming. In addition to these safeguards, you can set an anti-takeover option from RP which prevents certain keypad programming. Even a total default of the panel programming cannot reset the anti-takeover option once it is set.

3.4 Area Partitioning

The control may be divided into 1 to 8 independent areas (partitions). Each area appears as a full-featured system, allowing one control to be shared by multiple, independent departments within a common structure. Zones, User Codes, and Keypads may be assigned to any 1 area up to the maximum number available. An example is a single business divided into separate departments, each department occupied by different employees. Mount the control in a secure area (common utility closet) with dedicated and uninterrupted AC power and telephone service. Then assign zones, codes, and keypads to each department.

Output 1 siren/voice activates on all alarms, regardless of the area. The RP Software Rules can be used create additional (separate) outputs. When reporting to the central station events like AC Power Failure, Automatic tests, Low Battery, etc., are considered system reports and are transmitted using the Area 1 account number. If area partitioning is not desired, simply designate all zones to a single area (Area 1) which is the factory default setting for zones 1-16.

COMMON AREA - Another popular feature is the ability to have one or more areas made "common" to Area 1. This is often referred to as a "Vestibule Feature". Any of the Areas 2 thru 8 may be made common to Area 1. The result is: Area 1 cannot be armed until all its common areas are armed. Once armed, Area 1 will disarm if any common area becomes disarmed. This is good for lobbies or vestibules shared by two or more businesses. Each business must have their own area keypad.

NOTE: If you want Area 1 to automatically arm when all its common areas become armed, use a Whenever/And/Then rule from the RP software to do this.

3.5 Communicator Setup Checklist

The Communicator (Dialer) in the M1 can dial up to 4 telephone numbers in addition to the RP computer. The more powerful M1G can dial up to 8 phone numbers plus RP. Digital reporting formats include: Pulse 4+2, SIA, Contact ID, and Pager. There is also a Voice format which can be commanded from the RP Rules Programming to call a business, home, or cellphone and deliver a voice message. Use the following checklist for each required telephone number.

- Under Menu 08 - Telephone Account Setup, select one of the telephone numbers and program the following:
Option 01: Select the desired reporting format - 0=Disable, 1=Contact ID, 2=SIA, 3=Pulse 4+2, 4=Pager, 5=Voice.
Note: The Voice format (5) cannot be enabled from keypad programming. It can only be programmed from the Ness-RP Software using the Whenever/And/Then Rules.
Option 02: Set the priority for the first (primary number) to 0 = Always Report.
Option 03: Program the telephone number digits to be dialed. No special start or ending characters are required.
Option 04: Set the dial attempts to greater than 0. For Digital reports 8 is suggested. For Voice the max. is 2.
Option 05: Program the digits for the account number to report. Each area (partition) has its own Acct. Number.
Option 13: Select Yes to have Area info, Zone Alarms, Zone Restores, and Zone Unbypasses reported to this Tel #.
Option 14: Select Yes if you wish to have Zone Bypasses reported to this Tel #.
Option 15: Select Yes if you wish to have Zone Troubles reported to this Tel #.
Option 16: Select Yes if you wish to have User (Open/Close) Reports reported to this Tel #.
Option 17: Select Yes if you wish to have Global System Events (AC Fail, Low Battery, etc.) reported to this Tel #.
Option 18: Although not required, you may program a text name for each telephone number.
- Under Menu 09 - Area Reporting Codes, select the area (partition) and program the desired options such as: Dialer Delay, Alarm Abort, Auto Open/Closings, etc. then .
- Under Menu 10 - Zone Reporting Codes, select the zone number and program the desired options such as: Zone Alarms, Restores, Bypasses, or Trouble.
Option A: For Zone Alarm program a two digit code. To have the automatic SIA or Contact ID report codes transmitted simply program a nonzero value. I.E. Program a 1 (01).
Option R: For Zone Restore program a two digit code. For automatic SIA or Contact ID codes program a 1 (01).
Option B: For Zone Bypass program a two digit code. For automatic SIA or Contact ID codes program a 1 (01).
Option T: For Zone Trouble program a two digit code. For automatic SIA or Contact ID codes program a 1 (01).
- Under Menu 11 - F Key Reporting Codes, select and program the alarm code for each desired Keypad Panic Key. NOTE: Keypad Panics only have Alarm report codes, they do not have restore codes. For automatic SIA or Contact ID codes program a 1 (01).
- Under Menu 12 - Sys Report Code Options & Codes, select and program each desired option such as: AC Fail, Low Battery, Automatic Test, and other system wide options, including the time values for certain options. For automatic SIA or Contact ID report codes program a 1 (01).
- Under Menu 13 - User Report Codes, select and and program an Open or Close report code for any User(s) that you wish to track arm/disarm events, including arm/disarm by the Installer Code or Ness-RP computer.

3.6 Entering Installer Level Programming

- Press the center 'ELK' key once followed by the DOWN arrow key until display reads "9-Installation Programming". NOTE: The keypad may beep and display the following:
- Enter the Installer Program Code when required.
Press the right arrow key to select the "Installation Programming" option.



The Factory Default Installer Program Code is: 1 7 2 8 3 9

For security against unauthorized programming changes, the installer code should be changed from its factory default setting. This can be done from Menu 07 - Globals System Definitions, Option 42.

Once the Installer Code has been entered, the first programming menu will display and a 4 minute timer will be started. If there is no key-press activity during this time period the control will automatically exit from the programming mode. It is easy to navigate around and between the programming menus and options using the up and down arrow keys. When the correct menu or option is located, press the right arrow key to proceed into that menu.

Refer to the Quick Reference Guide on the following page to locate a particular menu or to see what options appear under each menu. Refer to the individual menus and their option descriptions for details about each of the programmable items.

ELK-M1 and ELK-M1G QUICK REFERENCE - MENU PROGRAMMING

<p>Menu 01 Bus Mod Enroll Enrolling -Disp Totat Modules -Allow Module Edit</p>	<p>Menu 02 User Code Auth. User 1 Area # (1) Arm (2) Disarm (3) Bypass (4) Access (5) Temporary (6) Master (7) Menu 1-5 (8) Menu 1-5 (9) Duress (10) [Name]</p>	<p>Menu 03 Area Defs Area 1 (1) Entry Delay 1 (2) Exit Delay 1 (3) Exit Delay 2 (4) Entry Delay 2 (5) Auto Stay (6) Exit Restart (7) Closing Ringback (8) SgIKey Quickarm (9) DilIKey Quickarm (10) Stay/KeyScroll (11) Stay Instant (12) Night Scroll (13) Night Instant (14) StayChgArmed (15) [Name]</p>	<p>Menu 04 Keypad Defs Keypad 1 (1) Area Assgn (2) Silent Entry (3) Silent Exit (4) Silent Chime (5) Dark in 60_sec (6) Show Date/Time (7) Show Temp (8) Show Area (9) Byp Req Code (10) F1 Key Def. (11) F2 Key Def (12) F3 Key Def (13) F4 Key Def (14) F5 Key Def (15) F6 Key Def (16) [Name]</p>	<p>Menu 05 Zone Defs Zone 1 (1) Definition (2) Type (3) Area Assign (4) Silent Alarm (5) Diater Delay (6) Listen-In (7) Bypass (8) Force Arm (9) Swinger (10) Per. Trip (11) Fast Loop (12) Chime (13) Cross_Zh (14) [Name]</p>	<p>Menu 06 Cutoff Timers (1) Burglar (2) Fire (3) Medical (4) Police (5) Carbon Mon (6) Emergency (7) Freeze (8) Gas (9) Heat (10) Water (11) Aux1 24hr (12) Aux2 24hr</p>	<p>Menu 07 Global Options (cont.) (26) Out 2 Change to Voltage (27) Out 2 Delay Time (28) Out 2 Sgl Alarm Lockout (29) Rings til Answer (30) Ring/Hang/Answer (31) 2 Way Listen-in Enable (32) 2 Way Callback Time (33) CS Alm Verify Time (34) Baud Rate Port 0 (35) Xmit Event Log (36) Xmit Zone Changes (37) Xmit Output Changes (38) Xmit Task Changes (39) Xmit Light Changes (40) Xmit Keypad Keys (41) Req Code User Menus 1-5 (42) Local Prog. Code (43) Serial Number [Read Only] (44) Software Ver. [Read Only] (45) Default Control Options (81) Default User Codes (82) Default Areas Data (83) Default Keypads Data (84) Default Zones Data (85) Default Zone Names (86) Default Cutoff Timers (87) Default Global Data (88) Default Telephone Data (89) Default Telephone Numbers (90) Default Area Report Codes (91) Default Zone Report Codes (92) Default System Report Codes (93) Default User Report Codes (94) Default Voice Messages (95) Default Wireless Definitions (96) Default Entire Control Panel</p>	<p>Menu 08 Telephone #'s & Accts Telephone #1 (1) Always Report (2) Number (3) Format (4) Attempts (5) Acct #1 (6) Acct #2 (7) Acct #3 (8) Acct #4 (9) Acct #5 (10) Acct #6 (11) Acct #7 (12) Acct #8 (13) Report Area/Alm /Res/Unbypass (14) Report Zn Bypass (15) Report Zn Troubles (16) Report User Op/Cl (17) Report Sys Globals (18) [Name]</p>	<p>Menu 09 Area Report Codes Area 1 (1) Dial Delay Time (2) Abort Code (3) Cancel Time (4) Cancel Code (5) Close Auto (6) Close Early (7) Close Extended (8) Fail to Close (9) Late Close (10) Keyswitch Close (11) Duress Code (12) Open After Alarm (13) Open Early (14) Fail to Open (15) Open Late (16) Keyswitch Open (17) User Lockout (18) Exit Error (19) Fail to Comm</p>	<p>Menu 10 Zone Rpt Codes Zone #1 Alarm Code Restore Code Bypass Code Trouble Code</p>	<p>Menu 11 Keypad Report Codes Keypad 1 (1) F1 Key Alarm (2) F2 Key Alarm (3) F3 Key Alarm (4) F4 Key Alarm (5) F5 Key Alarm (6) F6 Key Alarm</p>	<p>Menu 12 System Rpt Codes (1) AC Fail Delay (2) AC Fail Code (3) Auto Test Code (4) TstTime hr:mm (5) Days betweenTest (6) Aux Overcurrent (7) Exp Module Tbl (8) Installer Begin (9) Installer End (10) Log 80% Full (11) Low Battery (12) Memory Error (13) RP Download (14) Tel Line Fault (15) Output 2 Tbl</p>	<p>Menu 13 User Rpt Codes User #1 (1) Open Code Close Code</p>	<p>Menu 14 Wireless Defs User 100 - Installer- Close Code (1) Open Code Close Code User 101 - RP Computer Upload/Download (1) Open Code Close Code</p>
--	---	---	--	---	--	--	---	--	--	---	---	--	--

Menu 01 - Bus Module Enrollment



Press RIGHT arrow key to select this menu. Press UP or DOWN arrow keys to select another menu. The ELK key backs up one menu level. To exit press the * or Exit key.

NOTE: Every data bus device: Keypad, Input (Zone) Expander, Output Expander, etc. MUST have a unique address within its type. This menu is then used to enroll the device into the system. SEE DETAILS BELOW:

Bus Module Enroll



Description of Option

Press the RIGHT arrow key to select this menu and automatically start the bus enrollment process. ALL data bus devices which are presently connected to the data bus should become enrolled.



The enrollment process only takes a few seconds. Once complete, this summary screen will appear displaying the total number of bus modules that were found and enrolled. **To edit and/or view the devices individually, press the RIGHT arrow key one time.**



Each enrolled keypad/device can be viewed one by one. The first device will always be Keypad 1 with a T1 (for type 1) and Addr=01 (for address 01). As explained below, different kinds of devices can be identified by their device "Type". Pressing the Up or Down arrow keys will scroll through each enrolled device.



If a device is removed from the data bus, it should be removed by repeating the enrollment process. The control will only enroll the devices that are connected. It will remove any previously enrolled devices that it does not see.

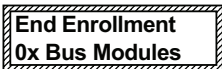

After the last device is reviewed, the next press of the Up arrow key moves to the "End Enrollment" screen which once again displays the total number of devices enrolled.

DATA BUS DEVICE TYPES AND ADDRESSES: Each data bus device is a specific "Device Type". Keypads are TYPE 1, Input (Zone) Expanders are TYPE 2, Output Expanders are TYPE 3, Serial Port Expanders are TYPE 5. Any new devices designed will be assigned a Device Type. Every data bus device MUST have a unique "Address" setting within its type. Valid Input Expanders addresses are 2 to 13, Output Expander addresses are 1 to 13. The address determines the starting and ending zone or output numbers for that expander. See chart below:

Addr	Input Exp	Output Exp	Addr	Input Exp	Output Exp.	Addr	Input Exp	Output Exp.
1	= N/A (main bd)	Outputs 1-16	6	= Zone 81-96	Output 65-80	11	= Zone 161-176	Output 161-176
2	= Zone 17-32	Output 17-32	7	= Zone 97-112	Output 97-112	12	= Zone 177-192	Output 177-192
3	= Zone 33-48	Output 33-48	8	= Zone 113-128	Output 113-128	13	= Zone 193-208	Output 193-208
4	= Zone 49-64	Output 49-64	9	= Zone 129-144	Output 129-144			
5	= Zone 65-80	Output 65-80	10	= Zone 145-160	Output 145-160			

INPUT AND OUTPUT EXPANDER ADDRESSES: Locate the bank of four white (DIP) switches along the top edge of the board. Each switch has a position of Off or On (0 or 1) and a binary value (1, 2, 4, 8). The addition of the binary values (sum total) for the switches set to the On position determines the data bus address. For example: Data bus address 5 is set by placing switches 1 and 4 to the On position (1 + 4 = 5). All other switches must be in the down or Off position.

KEYPAD ADDRESSES: All keypads are factory set to address 1. Valid addresses are 1 to 4 for the ELK-M1, or 1 to 16 for the ELK-M1G. The first keypad on the system (Keypad 1) is automatically enrolled upon power up. Each additional keypad must be assigned a unique address and then manually enrolled from "Menu 1 - Bus Module Enrollment". To set the address on a keypad do the following:

1. Hold down a key while applying power OR press and hold the (Asterisk) "*" and F5 keys for 5 seconds.
2. Press the F1 key, then use the UP or DOWN arrow keys to set the desired address number.
3. Press the EXIT key when done.

NOTE: If a device is removed from the data bus, it should be un-enrolled to prevent a trouble. To replace a defective device, set the address to the same value as the old unit and initiate the Bus Enrollment process.

Menu 02 - User Code Options

Press RIGHT arrow key to select this menu. Press UP or DOWN arrow keys to select another menu. The ELK key backs up one menu level. To exit press the * or Exit key.

02-UserCode Optn
Code used to: ▶

Default Code for User Code 1 is: 3 4 5 6 Note: If six digit code option is enabled, the default will be 1 2 3 4 5 6. See Menu 07 - Global System Definitions, Option G11

User Code Options

Description of Option

001: Sel ⇄ Prg ▶
User 1

There are 99 potential User codes. User 1 (001) is the first to display. Press the right arrow key to program, or press the up or down arrow keys to select another user. Enter three digits to jump to a specific user. The user name is displayed along the bottom.

001 01:12345678 ▶
Code used inArea

This option assigns the areas(s) in which this code may be used. For example: if the numbers 1,2, & 4 are displayed, the code may be used in those areas. To assign or remove an area press the numbers keys 1 thru 8. Each press toggles the number on/off.

001 02:=Yes
Arm with Code

Selects Arm privileges. If Yes, this code can Arm it's assigned area(s) (see option 01 above) from a keypad that is also assigned to the desired area. If No, this code cannot be used to Arm.

001 03:=Yes ▶
Disarm with Code

Selects Disarm privileges. If Yes, this user code can Disarm it's assigned area(s) (see option 01 above) from a keypad that is also assigned to the desired area. If No, this code cannot be used to Disarm.

001 04:=Yes ▶
Bypass with Code

A Yes allows this code to Bypass zones whenever Menu 04-Keypad Definitions, Option 09, "Byp Key Req PIN" is set to Yes. Code and Keypad must be in the same area. Default value for both these options is No (code not required for bypass).

001 05:=No ▶
Access with Code

A Yes allows this code to activate the Access Keypad Events 1313-1328 for the keypad where code is entered. Use the Whenever/And/Then Rules from Ness-RP to assign an output to this event for tripping a door strike or lock. **Note: If this code is enabled for arming, it will be necessary to press the Exit or Stay key to arm after the code.**

001 06:=No ▶
Temporary Code

If Yes, this code can only disarm if the control was armed by it or another temporary code. In other words: A temporary code cannot disarm the control if a regular code was used to arm. A temporary code might be used for cleaning, repair personnel, etc.

001 07:=Yes ▶
Master Code

A Master Code can be used to review, change, or delete other users, and to modify selected system options. Only one Master code is needed per system. For security purposed, multiple Master codes are not recommended.

001 08:=No ▶
Menu 1-5 Allowed

When Menu 07 - Global System Definitions, Option 41, "Require Code User Menu 1-5" is set to a Yes, this option is then used to set which codes are allowed to access Menus 1 - 5. **NOTE: Menus 6, 7, and 8 are only available to a Master or Installer code.**

001 09:=No ▶
Duress

If Yes, this code will cause a silent Duress or "holdup" alarm to activate when the code is used to arm or disarm the system. **CAUTION: The communicator report code MUST also be programmed! This feature is dangerous and should be used with caution.**

001 10:Usr Name◀
User1

To edit the User (Name) text press the left arrow key. Enter text using the number keys. I.E. For a "K" press the 5 key twice. To move the cursor, press the RIGHT or LEFT arrow keys. The Chime key inserts a space, the Bypass key erases 1 digit. The up/down keys to toggle between upper and lower case. Press the ELK key when complete.

Menu 03 - Area Definitions

Press RIGHT arrow key to select this menu. Press UP or DOWN arrow keys to select another menu. The ELK key backs up one menu level. To exit press the * or Exit key.

03-Area
Definitions ▶

Area Definitions

A1: Sel ◀ ▶ Prg▶
Area 1

Description of Option

Of the 8 potential areas (partitions), Area 1 is the first to display. Press the right arrow key to program, or press the up or down arrow keys to select another area. To jump to a specific area enter the number (1-8). The area name is displayed on the bottom.

A1 01:=060 ▶
Exit Delay1 Time

The amount of exit time in seconds for all zones programmed as Exit Delay 1. Range is 045 to 255 seconds. Default value is 060. **NOTE: Due to the way force arm works, if an Exit Delay 1 zone also has force arm enabled, its exit time will be the greater of the time values for Exit Delay 1 or Exit Delay 2. Do not enable force arm on Exit Delay 1 zones if this operation is not desired.**

A1 02:=030 ▶
Entry Delay1Time

The amount of entry delay time in seconds for zones programmed as Entry Delay 1. Range is 030 to 255 seconds. Default value is 030.

A1 03:=060 ▶
Exit Delay2 Time

The amount of exit delay time in seconds for zones programmed as Exit Delay 2. Range is 045 to 255 seconds. Default value is 060. **See note above regarding force arm and Exit Delay 1 zones.**

A1 04:=030 ▶
Entry Delay2Time

The amount of entry delay time in seconds for zones programmed as Entry Delay 2. Range is 030 to 255 seconds. Default value is 030.

A1 05:=No ▶
AutoStay No Exit

If Yes, the control will switch from AWAY mode to STAY mode at the end of the exit delay time if no exit zone is violated (no exit detected). **NOTE: This tracks the longest of the two exit timers.** All interior zones are bypassed in the STAY mode. Default value is No.

A1 06:=Yes ▶
Exit1TimeRestart

If this option is set to Yes (default), the exit procedures will be affected in three ways:

1) ADDITIONAL EXIT1 "GRACE" FEATURE - During the initial Exit Delay 1 time if the zone violates a second time and restores, the exit timer will automatically restart one time. I.E. If the Exit1 door is opened, closed, and then opened again the timer will restart. **NOTE: This only works on Exit Delay 1 zones and the timer only restarts one time. It does NOT work if the zone is enabled for force arm!** This features complies with the SIA CP-01 false alarm reduction standard.

2) SPOUSE "LEAVE FOR WORK" OR "LET PET OUT" FEATURE - If the system is armed in one of the Stay modes, a User may press the Exit key to re-start the exit delay time in order to open an exit/entry door and leave for work. The system remains in the Stay mode for remaining family members that are still in the house. This can also be used to let a pet outdoors. When the pet is ready to come back inside the User simply presses the Exit key again to restart the timer.





3) GOING FROM STAY MODE TO AWAY MODE - If the system is armed in one of the Stay modes, a User may change the arm mode to Away. This is done by pressing the Exit key twice in short succession (within 3 seconds) and leaving the building.

Exit Error If an entry/exit zone is violated at the time the Exit Delay time expires, the **Exit Error Feature** will be activated. The local siren will sound immediately and the Entry Delay warning will begin. If the control is not disarmed before the Entry Delay expires, the communicator will report the alarm along with an Exit Error code, provided these codes are programmed. An Exit Error event flag will also be set which can be used by the "Whenever/And/Then" rules (refer to the Ness-RP software) to sound a siren, or blink a light, or whatever. Exit Error feature complies with the SIA CP-1 false alarm reduction standard.

* SIA
CP-01

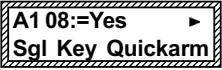
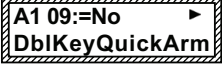
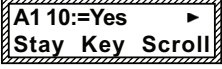
* SIA
CP-01

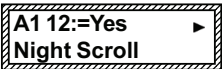
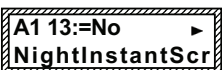
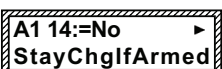
Menu 03 - Area Definitions (continued)

Area Definitions	Description of Option
	If Yes, a Closing Ringback signal (otherwise known as closing report successful) will be sent to all the keypads when the Communicator transmits a closing report and the Central Station Receiver kissoff (acknowledgement) is received. The Exit Delay time will be restarted at this time. The default value is No.
	If Yes, the control can be armed by a single press of the Exit or Stay keys. No code is required except to disarm. Note: This option cannot be set to Yes if "DbI Key Quick Arm" (see below) is set to Yes. The default value is Yes.
	If Yes, the system can be armed by a double press of the Exit or Stay keys. The second press must follow the first very quickly. Note: This option cannot be set to Yes if "Sgl Key Quick Arm" (see above) is set to Yes. The default value is No.
	If Yes, the Stay key may be pressed during the exit delay time to scroll (step) through the selected levels of Stay arming. I.E. Stay Instant, Stay Night, etc. The options below select the levels that will be available. The default value is Yes.
	If Yes, AND option 10 is set to Yes, multiple presses of the Stay key during exit delay will be able to scroll to the Stay Instant arming level. The default value is No.
	If Yes, AND option 10 is set to Yes, multiple presses of the Stay key during exit delay will be able to scroll to the Stay Night arming level. The default value is Yes.
	If Yes, AND option 10 is set to Yes, multiple presses of the Stay key during exit delay will be able to scroll to the Stay Night Instant arming level. The default value is No.
	This option should be used with caution. If Yes, the Stay key may be used to scroll or step the armed level after exit delay has expired and the control is fully armed. The default value is No.
	To program the text description of the Area (Name) press the left arrow key. Enter text using the number keys. I.E. For a "K" press the 5 key twice. To move the cursor press the right or left arrow keys. While programming the text, pressing the Chime key inserts a space, and the Bypass key erases 1 digit. The up and down arrow keys toggle between upper and lower case. Press the ELK key when complete.

VACATION MODE: During the exit delay time the Away key may be pressed to convert from Away mode to Away Vacation mode. The Away Vacation mode does not alter any of the security arming times or zones. Its primary purpose is for use with the Whenever/And/Then Rules programming of Ness-RP for enhanced energy savings modes.

AUTO ARMING: The control has an Auto Arming feature which may be setup using the "Whenever/And/Then Rules" in the Ness-RP PC Programming Software. Basically, a rule must be written to initiate the auto arm sequence at a specific time and/or date occurrence along with a programmable pre-warning time period. At the end of the pre-warn time, the system will automatically arm to the AWAY mode, bypassing any violated Burglar zones. All area keypad(s) will beep and display a warning when the initiating time occurs. Pressing the * key clears this warning for 1 minute. The auto arm time may be extended in 10 minute increments by pressing the RIGHT arrow key. No further warnings will occur until 10 minutes prior to the newly "extended" auto arm time. *Example 1:* If a scheduled AutoArm is set for 06:00pm with a pre-warn time of 20 minutes, the warning will start at 6:00pm and the auto arm will occur at 6:20pm. Pressing the RIGHT arrow key to extend the time will cause the new auto arm time to be 6:30pm.

Menu 04 - Keypad Definitions

Press RIGHT arrow key to select this menu. Press UP or DOWN arrow keys to select another menu. The ELK key backs up one menu level. To exit press the * or Exit key.

04-Keypad Definitions

Keypad Definitions

KP01: Sel ⇄ Prg ▶
Keypad 1

Description of Option

The ELK-M1 can have up to 4 Keypads. The ELK-M1G (Gold) can have up to 16 Keypads. Keypad 1 is the first display in this menu. Press the right arrow key to program or press the up or down arrow keys to select another keypad. To jump to a specific keypad enter the number (1-16). The keypad name is displayed on the bottom.

KP01 01:=1 ▶
Area Assigned To

A single keypad may only be assigned to work with a single area. Multi-area operation from a single keypad is a future enhancement. Select any area from 1 to 8. The default value is 1.

KP01 02:=No ▶
Silent on Entry

If Yes, the keypad will not produce an entry warning signal during entry delay time after violation of a delay 1 or delay 2 zone while armed. The default value is No.

KP01 03:=No ▶
Silent on Exit

If Yes, the keypad will not produce an exit warning tone during exit delay 1 or exit delay 2 times upon arming. The default value is No.

KP01 04:=No ▶
Silent on Chime

If Yes, the keypad will not produce any Chime tone even though the Chime mode may be on and a chime type zone is violated. This is good for a baby's room, etc. The default value is No.

KP01 05:=No ▶
Go dark in 60sec

If Yes, the keypad turns off it's Ready and Armed lights (goes dark) and blanks armed or disarmed indication on the LCD display 60 seconds after arming or no activity (button pushing). Any button press turns the indicators back on. The default value is No.

KP01 06:=Yes ▶
Show Date & Time

If Yes, the keypad will display the date and time on the bottom line of the LCD screen. If there is too much information to display at once, the bottom line of the LCD will alternate. The default value is Yes.

KP01 07:=Yes ▶
Show Temperature

If Yes, the keypad will display it's local temperature on the bottom line of the LCD screen. If there is too much information to display at once, the bottom line of the LCD will alternate. The default value is Yes.

KP01 08:=Yes ▶
Show Area Name

If Yes, the keypad will display the name of the area in which it belongs. If there is too much information to display at once, the bottom line of the LCD will alternate. The default value is Yes.

KP01 09:=No ▶
Byp Key Req PIN

If Yes, the Bypass key cannot be used unless a valid user code is entered. The default value is No.

Keypad F1, F2, F3, F4, F5, F6 keys Each keypad has 6 lighted function keys that may be programmed to activate specific operations. There are 7 programming attributes for each key: 1) KeyEvent - A four digit event code for the zone definitions 0001 thru 0035, or the automation tasks 2001 - 2032. 2) KeyLight - A four digit event code which lights the key when the event is active. This can be any of the Appendix A Event Codes. 3) Light Invert - A Yes/No option which allows the light to be opposite of the event, off when active, on when not. 4) Light Blink - A Yes/No option which allows the light to blink when active. 5) Key Requires PIN - A Yes/No option used to prevent the key from activating unless a valid user code is entered. 6) Single Key Press - A Yes/No option which allows a single press of the key instead of the normal double press to activate the event. NOTE: In the double press mode the key's name is displayed on the LCD screen as soon as the first press occurs. This serves to visually verify to the user that the correct key has been selected prior to the second "activating" key press. 7) Key Name - A sixteen character programmable description that describes the key's function. I.E. Police Alarm, Garage Door, etc.

Menu 04 - Keypad Definitions (continued)

Keypad Definitions

Description of Option

KP01 10:F1 Key Definitions

To program the F1 key definitions press the right arrow key. The program will branch off into the 7 options for this key. To select another option press the UP or DOWN arrow keys. To jump to a specific option enter the two digit number for that option.

**F1KeyEvent=0010
Evt=Fire Alarm**

Key Event refers to what the key activates. F Keys can be used to activate an Alarm, an Automation Task, or by Ness-RP Whenever/And/Then Rules to activate most anything. Press the RIGHT arrow key and enter 4 digits. Enter 0000 if Ness-RP is going to be used exclusively. Enter 0001-0036 for an alarm activation (see zone Defs), or 2001-2032 for an automation task activation (see Ness-RP software). The event description is displayed along the bottom. Press the RIGHT arrow key to move to the next option.

**F1KeyLight=1001
Evt=Fire Alarm**

Key Light selects the event which will cause the key to light up. See Event Codes in Appendix A. Press the RIGHT arrow key and enter 4 digits. The bottom line displays the description of the event. Press the RIGHT arrow key to move to the next option.

**F1 Key:=No
Light Invert**

Light Invert selects whether the key should be lighted when the event is On (normal) or when the event is Off (Inverted). Press the RIGHT arrow key and select 1 for Yes or 0 for No. Press the RIGHT arrow key to move to the next option.

**F1 Key:=No
Light Blink**

Light Blink selects whether the key should blink when lighted or be steady. Press the RIGHT arrow key and select 1 for Yes or 0 for No. Press the RIGHT arrow key to move to the next option.

**F1 Key:=No
Key Requires PIN**

Key Requires PIN selects whether the F key requires a valid user code prior to activation. Press the RIGHT arrow and select 1 for Yes or 0 for No. Press the RIGHT arrow key to move to the next option.

**F1 Key:=No
SingleKeyPress**

If this option is No, a single press of the F key will activate the event. If Yes, then two presses OR single press and hold 2 seconds is required. Press the RIGHT arrow and select 1 for Yes or 0 for No. Press the RIGHT arrow key to move to the next option.

**F1 Key Name
F1 = Fire**

The Key Name will be displayed whenever the F key is pressed. Press the LEFT arrow key and enter text using the number keys. I.E. For "K" press the 5 key twice. Move the cursor using the right or left arrow keys. The up or down arrow keys select between lower and upper case. Press the ELK key when complete.

KP01 11:F2 Key Definitions

If the F2 Key is to be used, repeat the steps above.

KP01 12:F3 Key Definitions

If the F3 Key is to be used, repeat the steps above.

KP01 13:F4 Key Definitions

If the F4 Key is to be used, repeat the steps above.

KP01 14:F5 Key Definitions

If the F5 Key is to be used, repeat the steps above.

KP01 15:F6 Key Definitions

If the F6 Key is to be used, repeat the steps above.

**KP01 16:KP Name
Keypad 1**

To edit the Keypad Name press the LEFT arrow key. Enter text using the number keys. I.E. For "K" press the 5 key twice. Use the RIGHT or LEFT arrow keys to move the cursor. The UP or DOWN keys select between lower and upper case. The Chime key inserts a space, and the Bypass key erases 1 digit. Press the ELK key when complete.

Menu 05 - Zone Definitions

Press RIGHT arrow key to select this menu. Press UP or DOWN arrow keys to select another menu. The ELK key backs up one menu level. To exit press the * or Exit key.

05-Zone
Definitions

Zone Definitions

ZN001: Sel ↕ Prg
Zone 001

ZN001 01:Def=01 ▶
Burg Entry/Exit1

Description of Option

There are up to 208 zones. Press the UP or DOWN arrow key to scroll and select a particular zone. To jump to any zone, enter the number from 001 to 208. The zone name will display along the bottom line. Press the right arrow to program the selected zone.

This first option is used to set the zone definition. To locate a different option press the up or down arrow key OR enter an option's number to jump directly to it. Press the right arrow key to program the selected option. The available definitions are:

Def	Zone Description	Operating Characteristics														
00	Disabled - Used to remove any unused zone(s). No need to put a jumper or resistor across the terminals.															
01	Burglar Entry/Exit 1 - For perimeter entry/exit doors. Allows a time delay to enter and exit during arm and disarm.															
02	Burglar Entry/Exit 2 - For perimeter entry/exit doors that require more time delay during arm and disarm.															
03	Burglar Perimeter Instant - Windows and perimeter openings. Activates an immediate Burglary alarm if tripped during ANY armed mode. Does not provide any exit or entry delay.															
04	Burglar Interior - For motion detectors, interior doors, etc. Creates an instant alarm if tripped during the AWAY arm mode. This zone type IS NOT ACTIVE during the STAY, STAY INSTANT, NITE, and NITE INSTANT arm modes.															
05	Burglar Interior Follower - For motions detectors, interior doors, etc. which may be in the keypad or entry pathway. If an entry delay zone is violated first, this zone will delay (Follow) also, otherwise it will create an instant alarm. This zone type IS NOT ACTIVE during the STAY, STAY INSTANT, NITE, and NITE INSTANT arm modes.															
06	Burglar Interior Nite - For motion detectors, interior doors, etc. which are not close to sleeping areas. The primary use of this zone type is for increased security when the user is home. Interior Nite zones ARE ACTIVE during the NITE and NITE INSTANT arm modes as well as the AWAY arm mode and will create an instant alarm if tripped. This zone type is NOT ACTIVE during the STAY or STAY INSTANT arm modes.															
07	Burglar Interior Nite Delay - For motion detectors, interior doors, etc. that are not close to sleeping areas. Same as an Interior Nite zone except that Interior Nite Delay zones will delay for the entry/exit delay 1 time period. Interior Nite zones ARE ACTIVE during the NITE and NITE INSTANT arm modes providing increased security when the user is home and in bed. However, if the user accidentally wanders into a Nite Delay zone the entry delay timer will start and the tone will sound, warning the user to disarm before a false alarm occurs. NOTE: If "Auto Stay,No Exit" is set to YES (see Area Definitions) and the system is armed in the Away mode, all interior zones will be bypassed if no exit is detected from the premises during the exit delay time.															
		Away	Stay	Stay Instant	Nite	Nite Instant										
	Burg Entry/Exit (1 or 2) Zone	A	A	AN	A	AN										
	Burg Perimeter (Instant) Zone	AN	AN	AN	AN	AN										
	Burglar Burg Interior Zone	AN	-	-	-	-										
	Burg Interior Follower Zone	A	-	-	-	-										
	Burg Interior Nite Zone	AN	-	-	AN	AN										
	Burg Interior Nite Delay Zone	AN	-	-	A	AN										
<table border="1"> <thead> <tr> <th colspan="2">QUICK VIEW OF ARMING MODES</th> </tr> </thead> <tbody> <tr> <td colspan="2">This illustrates the condition of Burg zone types in the various arm modes.</td> </tr> <tr> <td colspan="2">Legend: A = Armed</td> </tr> <tr> <td colspan="2">"-" = Not Armed,</td> </tr> <tr> <td colspan="2">AN = Armed, No Delay</td> </tr> </tbody> </table>							QUICK VIEW OF ARMING MODES		This illustrates the condition of Burg zone types in the various arm modes.		Legend: A = Armed		"-" = Not Armed,		AN = Armed, No Delay	
QUICK VIEW OF ARMING MODES																
This illustrates the condition of Burg zone types in the various arm modes.																
Legend: A = Armed																
"-" = Not Armed,																
AN = Armed, No Delay																
08	Burglar 24 hr - Intended for tamper switches, etc. Activates an immediate Burglary alarm if tripped anytime (during armed or disarmed state).															
09	Burglar 24 hr Box Tamper - Intended for control, siren, and bell box tamper switches. Activates an immediate Burglary Tamper alarm if tripped anytime (armed or disarmed state).															
10	Fire 24 hr Alarm - Intended for Fire alarm sensors such as smoke detectors, heat stats, pull stations, etc. Activates an immediate Fire alarm upon a short across the zone wires. A Fire Trouble will be activated if an open (break in the zone wires) should occur.															
11	Fire 24 hr 'Verified' - For smoke detectors in high-risk false alarm areas. Upon initial activation (short across the zone), the control ignores the alarm and removes smoke power for 5 seconds to reset the detectors. During this 5 seconds, and for 25 additional seconds afterwards, no alarms will be recognized from this zone. Following this is a 30 second verification time window, during which any additional activation will be regarded as verification of the initial alarm and the control will initiate a Fire Alarm. If the 30 seconds expires with no further activations, the entire process is cleared (reset). A Fire Trouble will be activated if an open (break in the zone wires) occurs.															
12	Fire 24 hr Supervisory - Intended for monitoring water control valves on fire sprinkler systems. Same as Fire 24hr except that a short across the zone activates a Fire Supervisory alarm. A Fire Trouble will be activated if an open (break in the zone wires) should occur.															
13	Auxiliary1 24 hr - This zone can trip anytime (armed or disarmed) and send a communicator report, but there is no audible alarm output or keypad indication provided. It is displayed in the event log. A Whenever/And/Then rule can be written from the RP software to do other things with this zone type. Resets upon restoral.															
14	Auxiliary2 24 hr - This zone can trip anytime (armed or disarmed) and send a communicator report, but there is no audible alarm output or keypad indication provided. It is displayed in the event log. A Whenever/And/Then rule can be written from the RP software to do other things with this zone type. Resets upon restoral.															

Menu 05 - Zone Definitions (continued)

Def	Zone Description	Operating Characteristics
15	Keyfob - Used when a wireless keyfob is enrolled into a receiver at this zone ID location.	
16	No Alarm - Intended for use in Whenever/And/Then rules from the Remote Programming RP software. This zone type DOES NOT ACTIVATE any alarm and is not logged in the Event log. No reset is required.	
17	Carbon Monoxide 24 hr - Activates an immediate Carbon Monoxide alarm if tripped anytime (armed or disarmed). The keypad will display the alarm as well as the event log. This type of alarm can be silenced/reset with a valid User Code. The audible alarm can be set in "Cutoff Timers".	
18	Emergency 24 hr - Similar to Def 17, this zone creates an alarm if tripped anytime (armed or disarmed).	
19	Freeze Alarm 24 hr - Similar to Def 17, this zone creates an alarm if tripped anytime (armed or disarmed).	
20	Gas Alarm 24 hr - Similar to Def 17, this zone creates an alarm if tripped anytime (armed or disarmed).	
21	Heat Alarm 24 hr - Similar to Def 17, this zone creates an alarm if tripped anytime (armed or disarmed).	
22	Medical Alarm 24 hr - Activates an immediate Medical alarm if tripped anytime (armed or disarmed).	
23	Police Alarm w/Indication 24 hr - Activates an audible Police (Holdup) alarm if tripped (armed or disarmed).	
24	Police Alarm no Indication 24 hr - Activates a non-audible Police (Silent) alarm if tripped (armed or disarmed).	
25	Water Alarm 24 hr - Activates an immediate Water alarm if tripped anytime (armed or disarmed).	
26	Keyswitch Momentary - Intended for a spring loaded momentary key switch. Toggles the armed state (disarmed/armed) with each trip.	
27	Keyswitch Momentary - Away Mode - Intended for a spring loaded momentary key switch. Arms the area in the AWAY mode with each trip.	
28	Keyswitch Momentary - Stay Mode - Intended for a spring loaded momentary key switch. Arms the area in the STAY mode with each trip.	
29	Keyswitch Momentary - Disarm Only - For a spring loaded momentary key switch. Disarms with each trip.	
30	Keyswitch On/Off (Maintained) - Intended for a 2 position On/Off key switch. Arms the area in Open position. Disarms the area in the Closed position.	
31	Mute All Area Audibles - For silencing all area audibles by a two-way listen-in module (other manufacturer).	
32	Power Supervisory 24 hr - For supervising an external power supply which provides alarm/trouble contacts. Wire the power supply contacts to short the zone in a Low Battery event and open the zone in an AC Failure event.	
33	Temperature - For use with M1ZTS Temperature Sensors.(Ness part # 101-229 & 101-230) Requires the use of Whenever/And/Then rules from the Ness-RP software. NOTE: This definition is for ZONES 1 thru 16 ONLY!	
	Temperature zones must be set to FAST LOOP (less than 200ms) response.	
34	Analog - For sensors that produce a variable voltage (0 to 12 volt range). Requires the Whenever/And/Then rules from the Ness-RP software. NOTE: This definition is only available with the ELK-M1G (Gold) control.	

ZN001 02:Type=0
0=EOL Supervised

"Type" refers to the wiring configuration for zones. For Burglar and Keyswitch zones the valid types are: 0=EOL Supervised, 1=Normally Closed, 2=Normally Open, 3=EOL Security (Day) Alert on Open, or 4=EOL Security (Day) Alert on Short. For ALL other non-fire zones the types may be 0, 1 or 2 only. Fire zone valid types are: 5=EOL Supervised 4-wire detectors, 6=EOL Supervised 2-wire detectors (zone 16 ONLY!)

Type	Wiring Configuration	Operating Description
0	EOL Supervised , 2,200 Ohm resistor (Zones 1 - 16 are defaulted to Hwd 0)	
1	Normally Closed only . No resistor required.	
2	Normally Open only . No resistor required.	
3	EOL Supervised with Security (Day) Alert on Open. (Burglar & Keyswitch Zones Only) If zone wiring is OPENED while the control is disarmed the Keypad will beep and display the zone name. Ideal for gun cabinets, exit doors, etc. Press the Star key to silence beep. User code is required to acknowledge/reset the alert. A regular alarm is created if the control is armed. Requires the Whenever/And/Then rules from RP software for additional output.	
4	EOL Supervised with Security Day Alert on Short. (Burglar & Keyswitch Zones Only) Same as type 3 except the zone wiring must be SHORTED while the control is disarmed to create the alert. Pressing the Star key silences. A User code is required to acknowledge/reset the alert. A regular alarm is created if the control is armed. Requires the Whenever/And/Then rules from RP software for additional output.	
5	Fire, 4-Wire Smoke Detector with 2,200 Ohm EOL resistor. Trouble on open, alarm on short. (Zones 1 to 16).	
6	Fire, 2-wire Smoke Detector with 680 Ohm EOL resistor. (ZONE 16 ONLY)	

ZN001 03:Area=1
[Area Name]

Enter the area (partition) number that this zone is to be assigned to. A zone can only reside in one area and fire zones can only reside in Area 1.

ZN001 04: =No
Silent Alarm

A zone programmed 'Yes' for Silent Alarm will not cause any audible alarm event from a programmable output OR from any keypad. However, a visual display will occur on the keypad(s) which are assigned to the same area as the zone.

Menu 05 - Zone Definitions (continued)

Zone Definitions

Description of Option

ZN001 05: =Yes ▶
Dialer Delay

Dialer delay is designed to reduce false alarm dispatches. Upon an alarm from a zone with this option the communicator delays dialing for the "Dialer Delay" time programmed in Menu 09-Area Reporting Codes. If a valid code is entered before this delay expires, the report will ABORT (no report). If an "Alarm Abort" code is programmed, (see Menu 09), the communicator will transmit this in place of the alarm. NOTE: The Dialer Delay Time will only start once per alarm, regardless of additional zone trips. Default setting is No.

ZN001 06: =No ▶
Enable Listen-In

Allows zone to trigger a listen-in session after alarm is reported. Control will hold the line for 60 seconds after 'kiss-off', allowing Central Station to enter *55* to activate listen-in. The Central Station can renew or terminate listen-in remotely. NOTE: Two-Way must be enabled (Menu 07-Globals) and an interface (Ness-M1TWI Part # 101-216) with one or more microphone/speakers (Ness-M1TWS part # 101-219) must be installed. Default setting is No.

ZN001 07: =No ▶
Zone Bypassable

A Yes allows zone to be manually bypassed. A bypassed zone will be ignored by the system. Burglar zone bypasses are canceled upon a disarm. To bypass a zone: Press the Bypass key + [zone number] + the Bypass key once again. Default setting is Yes.

ZN001 08: =No ▶
Force Armable

Force Arm allows a violated zone to be temporarily bypassed upon arming. Prior to arm, the READY light blinks if force arm zone(s) are the only zones violated. Force arm requires two entries of a user code. Quick arm cannot be used for force arming. Upon the first code entry the keypad will display READY FORCE. The second code entry will force arm. Force armed zone(s) automatically return to service if they become normal while armed. **CAUTION! Force arm operates in a unique way on entry/exit zones!** - Entry/Exit zones that are also force armable can be violated during the exit delay and still become force armed. This allows a user to arm, open a garage door, back out, and then shut the door at their leisure, without creating a false alarm and without a long exit delay time. As soon as the garage door is closed, it will automatically return to service. Default setting is No. **NOTE: For UL installations Force Arm shall be disabled.**

ZN001 09: =No ▶
SwingerShutdown

Swinger Shutdown prevents a runaway communicator by shunting a zone after two trips. It cannot send another alarm until the control is reset OR a 48 hour time period elapse. Default setting is No. **NOTE: For UL installations this feature shall be disabled.**

ZN001 10: =No ▶
Req PeriodicTrip

This type zone must be tripped at least once per disarm cycle*. This prevents blocked PIRs or seldom used doors from being left not secure. Keypad will display "Not Ready" if a periodic zone has not been tripped. * NOTE: A periodic trip will not be required for a disarm period of 1 hour or less. Default setting is No.

ZN001 11: =No ▶
FastLoopResponse

Response is the time the zone must be violated before the system detects it. If No, the zone responds to the Slow response time. The time values are in milliseconds and they are programmed in the Menu 07 Global Sys. Definitions menu. Default setting is No.

ZN001 12: =No ▶
Enable Chime

Each zone may be selected to be included in the Chime annunciation whenever Chime Mode is turned on from the keypad. Most zone types may be included via this option. Default setting is No.

ZN001 13: =No ▶
In CrossZonePool

Burglar zones programmed "In CrossZonePool" cannot cause an alarm unless another zone in the cross zone pool also activates within a time window OR unless "Cross Zone Self Ver" is Menu 07 - Global System Definitions. **Entry/exit zones should NOT be programmed as Cross zones.** Default setting is No.

ZN001 14: Name ◀
Zone 001

To program the text description of the Zone (Name) press the left arrow key. Enter text using the number keys. I.E. For a "K" press the 5 key twice. To move the cursor press the right or left arrow keys. While programming the text, pressing the Chime key inserts a space and the Bypass key erases 1 digit. The up and down arrow keys move between upper and lower case. Press the ELK key when complete.

Menu 06 - Alarm Duration Timers

06-Alarm Cutoff Timers

Press RIGHT arrow key to select this menu. Press UP or DOWN arrow keys to select another menu. The ELK key backs up one menu level. To exit press the * or Exit key.

Each alarm type has a duration timer for cutting off the alarm after a programmable time period. Any output assigned to the alarm type will turn on when the alarm activates and will turn off when the alarm cutoff timer expires. If multiple alarm types are assigned to a single output, all alarms must turn off before the output can turn off. The range in seconds is 00000 to 65535. 00000=Never turn on. 65535=Never turn off NOTE: 65535 seconds is 1,092 minutes or 18.2 hours.

Alarm Cutoff Timers

Description of Option

CT01:=00600 sec ▶ BurgDuration

Burglar Alarm duration time in seconds. Default time is 00600 sec. (10 min.). Burglar always activates Siren/Voice Output (Out1) and Siren Output (Out2). Additional outputs may be programmed using the RP software "Rules" function.

CT02:=00000 sec ▶ FireDuration

Fire Alarm duration time in seconds. Default time is 65535 sec. (never cutoff). Fire always activates Siren/Voice Output (Out1) and Siren Output (Out2). Additional outputs may be programmed using the RP software "Rules" function.

CT03:=00600 sec ▶ Med Duration

Medical Alarm duration time in seconds. Default time is 00600 sec. (10 min.). Medical always activates Siren/Voice Output (Out1) and Siren Output (Out2). Additional outputs may be programmed using the RP software "Rules" function.

CT04:=00600 sec ▶ Pol Duration

Audible Police Alarm duration time in seconds. Default time is 00600 sec. (10 min.). Audible Police always activates Siren/Voice Output (Out1) and Siren Output (Out2). Additional outputs may be programmed using the RP software "Rules" function.

CT05:=00600 sec ▶ CO Duration

CO (Carbon Monoxide) Alarm duration time in seconds. The default time is 00600 sec. (10 min.). This alarm type is not preassigned to any outputs. The RP software "Rules" function must be used to assign outputs.

CT06:=00600 sec ▶ EmerDuration

Emergency Alarm duration time in seconds. The default time is 00600 sec. (10 min.). This alarm type is not preassigned to any outputs. The RP software "Rules" function must be used to assign outputs.

CT07:=00600 sec ▶ FrezDuration

Freeze Alarm duration time in seconds. The default time is 00600 sec. (10 min.). This alarm type is not preassigned to any outputs. The RP software "Rules" function must be used to assign outputs.

CT08:=00600 sec ▶ Gas Duration

Gas Alarm duration time in seconds. The default time is 00600 sec. (10 min.). This alarm type is not preassigned to any outputs. The RP software "Rules" function must be used to assign outputs.

CT09:=00600 sec ▶ HeatDuration

Heat Alarm duration time in seconds. The default time is 00600 sec. (10 min.). This alarm type is not preassigned to any outputs. The RP software "Rules" function must be used to assign outputs.

CT10:=00600 sec ▶ WatrDuration

Water Alarm duration time in seconds. The default time is 00600 sec. (10 min.). This alarm type is not preassigned to any outputs. The RP software "Rules" function must be used to assign outputs.

CT11:=00600 sec ▶ Aux1Duration

Aux 1 Alarm duration time in seconds. The default time is 00600 sec. (10 min.). This alarm type is not preassigned to any outputs. The RP software "Rules" function must be used to assign outputs.

CT12:=00600 sec ▶ Aux2Duration

Aux 2 Alarm duration time in seconds. The default time is 00600 sec. (10 min.). This alarm type is not preassigned to any outputs. The RP software "Rules" function must be used to assign outputs.

Menu 07 - Global System Definitions

Press RIGHT arrow key to select this menu. Press UP or DOWN arrow keys to select another menu. The ELK key backs up one menu level. To exit press the * or Exit key.

07-Global System Definitions

Global Sys Definitions

Description of Option

G01: =0 TelRmtCtl
In&OutsidTeleCtl

Telephone Remote Control allows any phone to become a basic keypad. This feature can be set for interior use only (1), interior & exterior use (2), or disabled (0). The M1VB Voice Module (standard on most units) is required for this feature. Default is (0) disabled.

G02: =Yes
12Hr Time Disp

Keypads that are programmed to show time and date on their second display line will either display 12 hour format or 24 hour military format, depending upon this option. Default is Yes

G03: =No
DD/MM Date Disp

If this option is No, the date will display as Month/Day/Year. If this option is Yes, the date will display as Day/Month/Year. Default No.

G04: =No
Celcius TempDisp

Keypads that are programmed to show temperature on their second display line will either display as Celsius or Fahrenheit, depending upon this option. Default is No.

G05: =Yes
Daylight Savings

The system will automatically adjust its internal clock for daylight savings time changes if this option is set to 'Yes'. Default is Yes.

G06: =0040 ms
Fast Loop Resp

Sets the time that a "Fast Loop" zone must remain open before the control responds. To set, press the RIGHT arrow key and enter a number from 002 to 255. Time is adjusted in 10 millisecond increments from 20ms to 2550ms (2.55 seconds). Default is 40ms.

G07: =0400 ms
Slow Loop Resp

Sets the time that a "Slow Loop" zone must remain open before the control responds. A "Slow Loop" zone is basically any zone that does not have the "FastLoopResponse" option enabled in Menu 05 - Zone Definitions. To set, press the RIGHT arrow key and enter a number from 002 to 255. Time is adjusted in 10 millisecond increments from 20ms to 2550ms (2.55 seconds). Default is 400ms.

G08: =No
CrossZoneSelfVer

Zones programmed with the 'Cross Zone' option may be allowed to self-verify an alarm condition. I.E. A second trip of the same zone within the Cross Zone Verify Time window will be considered a verified alarm. Default is No.

G09: =030
CrossZoneVerTime

This timer function is the amount of time in seconds that is allowed for two or more 'Cross Zone' zones to verify each other in an alarm condition OR for a second trip of the same zone when 'CrossZoneSelfVer' has been enabled. Default is No.

G10: =Yes
Audible Troubles

This option selects whether ordinary non-fire system troubles will cause audible alerts to sound. This option does not affect fire trouble conditions, which will always be audible. Default is No.

G11: =No
6 Digit UserCode

The M1 supports up to 99 User codes, plus the Installer code. The User codes can be either 4 digits in length or 6 digits, depending upon this option. Default is No (4 digits). **NOTE: The Installer code is ALWAYS 6 digits.**

G12: =99 Digits
WrongCodeLockout

To prevent a would be thief or hacker from being able to hunt for a valid user code, the system can automatically lock out all code entry for 1 minute after a sequence of invalid digits. The range of value can be set from 13 to 99. Default is 99.

Menu 07 - Global System Definitions (continued)

Global Sys Definitions

Description of Option

G13: _____ ▶
Common To Area1

Any of the Areas 2 thru 8 may be made common to Area 1. The result is: Area 1 cannot be armed until all its common areas are armed. Once armed, Area 1 will disarm if any common area becomes disarmed. This is good for lobbies or vestibules shared by two or more businesses. Each business must have their own area keypad. **NOTE: If you want Area 1 to automatically arm when all its common areas become armed, use a Whenever/And/Then rule from the RP software to do this.**

G14: =No Out1&2▶
Chg YelpToBuzzer

Changes the Burglar Yelp sound on outputs 1 & 2 to a pulsing Buzzer sound. **NOTE: Out1 is designed for 8 Ohm - 20 watt min. speakers (up to 4 max) and has adjustable volume settings.** Default is No.

G15:=1 Out1Start ▶
Alarm Volum-Tst▶

Options G15 thru G18 set the start and final volume levels for alarms and non alarms. G15 sets the initial siren/bell volume of Output 1 upon initial alarm activation. The range of settings is selectable from 0 to 7 (0 = lowest, 7 = loudest).

G16:=7 Out1 Max ▶
Siren Volum-Tst ▶

Sets the maximum siren/bell volume of Output 1. The sound starts at the initial setting and increases (volume step) every 10 seconds until the max. is reached. Volume stepping reduces noise and confusion with user caused false alarms. Default is 7.

G17:=5 Out1 Max ▶
VoiceAlmVol-Tst ▶

Sets the maximum volume of Output 1 for Voice alarm messages. Just as in G16, with a low initial setting, the voice alarm message starts low and automatically increases (volume stepping) over a period of time until the max. is reached. Default is 5.

G18:=2 Out1 Non▶
AlmVoiceVol-Tst▶

Sets the maximum volume of Output 1 for Voice non-alarm messages. Non-alarm messages consist of system status, zone status, and various operating helpful hints that are produced for the user during non-alarm conditions. Default is 2.

G19:=No Out1 ▶
SuppressAllVoice

Selects whether or not voice messages are to be spoken through Output 1. Selecting "Yes" completely eliminates all spoken voice messages from Output 1. Selecting "No" allows voices to be spoken based upon the settings of G20 through G25. Default is No.

G20:=Yes Out1 ▶
SaySystemMessages

Selects whether System "non-alarm" messages will be spoken through Output 1. System messages include: "System is Armed", "System is Disarmed", etc. Default is Yes.

G21:=Yes Out1 ▶
Say Alarms

Selects whether Alarm messages will be spoken through Output 1.

G22:=Yes Out1 ▶
Say Zone Status

Selects whether Zone status messages will be spoken through Output 1.

G23:=Yes Out1 ▶
SaySystemTrouble

Selects whether System Trouble messages will be spoken through Output 1.

G24:=Yes Out1 ▶
Say Zone Trouble

Selects whether Zone Trouble messages will be spoken through Output 1.

G25:=Yes Out1 ▶
Say Chime

Selects whether Chime Event messages will be spoken through Output 1.

Menu 07 - Global System Definitions (continued)

Global Sys Definitions

Description of Option

G26: =No ▶
Out2 Voltage Out

Allows Output 2 to be converted from a siren driver into a voltage only output. If set to "No" the control produces alarm sounds for use with 8 Ohm speakers. If set to "Yes" the control will produce +12 Volts for use with self-contained sirens or bells. Default is No.

G27: =000sec Out2▶
Delay Turn-On

Ordinarily, Outputs 1 & 2 activate immediately on alarms. However, Output 2 can be time delayed up to 255 seconds. Using Output 1 strictly for interior sounders and Output 2 for outside sounders, a false alarm will be heard inside first, giving the user time to disarm before any outside sounders are activated. A "good neighbor" feature. Default is 000.

G28: =No Out2 ▶
SingleAlmLockout

Output 2 can be set to alarm only once per armed cycle for burglary type alarms. This feature is intended for noise abatement. The dialer will continue to transmit all alarms that may occur. **THIS ONLY LOCKS OUT AUDIBLE FROM OUTPUT 2.**

G29: =00 Rings ▶
Until Auto Answer

The control must be set to auto answer an incoming call in order for Telephone Remote Control or the Remote Programming (RP) to be accessed remotely. The range of rings can be set from 1 to 15. A value of "0" disables auto answer.

G30: =No ▶
Ring/Hang/Answer

A Yes enables faster connection from an outside telephone. It works as follows: Call the control and hang up after 1 or 2 rings. This starts a 45 second timer. Call the control a 2nd time *during this 45 second time* and the control will answer on the first ring. In some cases this Ring/Hang/Answer option may be the only way to get around telephone company provided answering services. **Option 29 MUST also be set!**

NOTE: If an on-site answering machine picks up, the RP software and the control will automatically attempt to override the machine using tone sniffing methods.

G31: =No 2Way▶
Listen-In Enable

Set this option to Yes ONLY when an M1TWI Two Way Listen-In interface (Ness part # 101-216) is installed. This enables the correct software commands and procedures to make the two way functional. Refer also to the instructions that are shipped with the M1TWI

G32: =00sec 2Way▶
CallbackTime

If Two Way is enabled, this timer provides a window for the CS to enter * 55 * and activate two way listen-in by holding the phone line off-hook for 001 to 255 seconds after a kissoff. Upon hangup, this timer re-starts to provide a window for the CS to callback and initiate two way. Control will answer an incoming call on the first ring. Enter 000 to disable.

G33: =000sec CS ▶
Verify Call Time

Allows the Central Station alarm verification by suspending (holding) new alarms after the initial alarm kissoff. The phone line is kept free for this time period. The time value can be from 001 to 255 seconds. Long time periods are not recommended. Enter 000 to disable.

G34: =9 115200 ▶
Baud Rate Port 0

This location is used to select the initial (default) baud rate for the on-board RS-232 serial port which is Port 0. The available baud rates are: 0 or 1=300 baud, 2=1200, 3=2400, 4=4800, 5=9600, 6=14400, 7=19200, 8=38400, and 9=115200

G35: =No Xmit ▶
Event Log - ASCII

The control can transmit ASCII data via it's RS-232 port to automation types of equipment. The ELK ASCII Protocol document is available upon request. This first option sets the control to transmit all event log information immediately as it occurs.

G36: =No Xmit ▶
Zone Chgs - ASCII

This option sets the control to transmit zone status changes immediately as they occur. The ELK ASCII Protocol document is available upon request.

G37: =No Xmit ▶
OutputChgs-ASCII

This option sets the control to transmit output status changes immediately as they occur.

Menu 07 - Global System Definitions (continued)

Global Sys Def

Description of Option

**G38:=No Xmit
Task Chgs - ASCII**

This option sets the control to transmit automation task status changes immediately as they occur.

**G39:=No Xmit
Light Chgs-ASCII**

This option sets the control to transmit automation lighting status changes immediately as they occur.

**G40:=No Xmit
Keypad Key Chgs**

Sets the control to transmit keypad key changes. This includes the Chime, Bypass, Exit, Stay keys, the ELK key and it's surrounding arrow keys, and the F keys. It does not transmit any of the numeric keys..

**G41:=No Require
Code UserMenu1-5**

Allows User Menus 1 through 5 to be blocked from view until a valid User code is entered. If set to "Yes", only User Codes which have the "Menu 1-5 Allowed" option enabled will be able to view or access Menus 1 through 5. Default is No.

**G42:=172839
Local Prog Code**

This is the 6 digit Installer program code that is required in order to access the local installer programming mode. **NOTE: Be careful when changing this code as it will be impossible to program the panel if the code is programmed wrong or forgotten.**

**G43:=D1234567
Serial Number**

This is a read-only location. Each control is assigned a unique serial number for identification of the unit regarding warranty, technical support, anti-takeover, and other issues that may arise.

**G44:xxxxxxxxxxx
Axxxxx Bxxxxx**

This is a read-only location displaying information about the current software and bootloader revision that the control is operating with. This will only be needed with the assistance of a factory technical support person.

**G45:=DefaultCtl
81=User Codes**

This option allows factory default values to be restored by individual menus/categories. Press the right arrow to select this option, then press the up or down arrow keys to scroll through the choices. To factory default any single category enter the displayed number. For example, entering 81 from this screen will cause all the User Codes to be factory defaulted. Please be patient as it may take a minute or more to default some items.

82=Areas Data

Entering 82 from this screen causes all area definitions to be factory defaulted.

83=Keypads Data

Entering 83 from this screen causes all keypad definitions to be factory defaulted.

84=Zones Data

Entering 84 from this screen causes all zone definitions to be factory defaulted.

85=Zone Names

Entering 85 from this screen causes all zone names to be factory defaulted.

86=CutoffTimes

Entering 86 from this screen causes all the cutoff timers to be factory defaulted.

87=Global Data

Entering 87 from this screen causes all global system defs to be factory defaulted.

88=TeleAcct Data

Entering 88 from this screen causes all telephone reporting setup to be factory defaulted.

89=Tele #'s Only

Entering 89 from this screen causes all telephone numbers ONLY to be factory defaulted.

90=AreaRptCodes

Entering 90 from this screen causes all area report codes to be factory defaulted.

91=ZoneRptCodes

Entering 91 from this screen causes all zone report codes to be factory defaulted.

92=SysRptCodes

Entering 92 from this screen causes all system report codes to be factory defaulted.

93=UserRptCodes

Entering 93 from this screen causes all user report codes to be factory defaulted.

94=VoiceMessages

Entering 94 from this screen causes all voice messages to be factory defaulted.

95=WirelessDef

Entering 95 from this screen causes all wireless definitions to be factory defaulted.

99=Entire Panel

Entering 99 from this screen causes the entire panel programming to be factory defaulted.

Menu 08 - Telephone Account Setup

Press RIGHT arrow key to select this menu. Press UP or DOWN arrow keys to select another menu. The ELK key backs up one menu level. To exit press the * or Exit key.

08-Telephone
Account Setup ▶

Telephone Acct Setup

Description of Option

T1: Sel ◀ Prg ▶
[Name for Tel#1]

The ELK-M1 provides up to 4 regular phone numbers plus 1 number for Ness-RP remote programming software. The ELK-M1G (Gold) provides up to 8 regular phone numbers plus the Ness-RP number. Each of the regular phone numbers can be used to report alarms, troubles, closings, opening, etc. in digital format as well as pager and voice formats. Using the up/down arrow keys, select the appropriate telephone number, then press the right arrow key to begin the programming options, starting with option 01.

T1: 01:Format=0 ▶
0=Disabled

This selects the reporting format to be used with this number. The available formats are:
00 = Disable reporting 01 = Contact ID 02 = SIA
03 = Pulse 4+2 04 = Pager DTMF tones 05 = Voice Message

Note: Voice Message (Voice Dialer) Format can only be selected from the Ness-RP Computer software. The activation of a voice messages requires a Whenever/ And/Then Rule from the Ness-RP software. See Section 4.3.

T1: 02: = 0 ▶
0=Always Report

Two choices: 0=Always Report or 1=Backup. Always Report means the number will always be dialed when its "report to" options are activated. Backup means the number will ONLY be dialed if the previous sequential number fails to complete its call. When backup is selected the "report to" options will be copied from the previous number and ONLY the name, number, format, and dial attempts may be edited. To edit any "report to" options you must temporarily set this value to 0. **NOTE: Telephone # 1 cannot be set as a backup since it is the first number. A backup cannot have another backup.**

T1: 03:Num=

These are the digits to dial for the selected telephone number. Up to 20 digits may be programmed. Valid number digits are: 0, 1, 2, 3, 4, 5, 6, 7, 8, and 9. In addition, special characters may be entered such as comma (,) for 2 sec. pause, slash (/) for 125 msec wait, # and * for touchtone signaling, plus the letters A, B, C, & D. The cursor automatically moves right each time you enter a number digit. To enter a special character place the cursor where you want the character and press the up arrow key. The 1 key produces a 1, #, *, and /. The 2 key produces a 2, A, B, and C. The 3 key produces a 3, and a D. When finished with a special character you must press the down arrow key to return to number digits.

T1: 04: = 08 ▶
Dial Attempts

This sets the number of dial attempts (re-dials) that the communicator will make to this number before a Comm Fail (fail to report) is logged. Valid range is 01 to 15 attempts. Default is 08.

T1: 05:=000000 ▶
Acct # for Area1

The Account number for Area 1 (up to 6 digits) when it is reported to this telephone number. Since all 6 digits must be entered, enter leading zeros (0's) if a shorter account number is required.

T1: 06:=000000 ▶
Acct # for Area2

The Account number for Area 2 (up to 6 digits) when it is reported to this telephone number. Since all 6 digits must be entered, enter leading zeros (0's) if a shorter account number is required.

T1: 07:=000000 ▶
Acct # for Area3

The Account number for Area 3 (up to 6 digits) when it is reported to this telephone number. Since all 6 digits must be entered, enter leading zeros (0's) if a shorter account number is required.

Menu 08 Telephone Account Setup (continued)

Telephone Acct Setup

Description of Option

T1: 08:=000000 ▶
Acct # for Area4

The Account number for Area 4 (up to 6 digits) when it is reported to this telephone number. Since all 6 digits must be entered, enter leading zeros (0's) if a shorter account number is required.

T1: 09:=000000 ▶
Acct # for Area5

The Account number for Area 5 (up to 6 digits) when it is reported to this telephone number. Since all 6 digits must be entered, enter leading zeros (0's) if a shorter account number is required.

T1: 10:=000000 ▶
Acct # for Area6

The Account number for Area 6 (up to 6 digits) when it is reported to this telephone number. Since all 6 digits must be entered, enter leading zeros (0's) if a shorter account number is required.

T1: 11:=000000 ▶
Acct # for Area7

The Account number for Area 7 (up to 6 digits) when it is reported to this telephone number. Since all 6 digits must be entered, enter leading zeros (0's) if a shorter account number is required.

T1: 12:=000000 ▶
Acct # for Area8

The Account number for Area 8 (up to 6 digits) when it is reported to this telephone number. Since all 6 digits must be entered, enter leading zeros (0's) if a shorter account number is required.

THE FOLLOWING 5 OPTIONS DEFINE WHAT IS REPORTED BY THIS TELEPHONE

T1: 13:=Yes Rpt ▶
AreaAlms,RestUnbp

This YES or NO option identifies whether this telephone number should report misc. options from the AREA REPORTING CODES menu, Zone Alarms, Restores, and Unbypasses from the ZONE REPORTING CODES menu, and Keypad Alarms from the KEYPAD F-KEY REPORTING CODES menu.

T1: 14:=No Rpt ▶
Bypasses

This YES or NO option identifies whether this telephone number should report the Zone Bypasses from the ZONE REPORTING CODES menu.

T1: 15:=No Rpt ▶
Zone Troubles

This YES or NO option identifies whether this telephone number should report the Zone Troubles from the ZONE REPORTING CODES menu.

T1: 16:=No Rpt ▶
User ReportCodes

This YES or NO option identifies whether this telephone number should report the user opening and closing codes from the USER REPORTING CODES menu.

T1: 17:=Yes Rpt ▶
Global SysEvents

This YES or NO option identifies whether this telephone number should report the global system event codes from SYS REPORT OPTIONS & CODES menu.

T1: 18:Name ◀
[Name for Tel#1]

To edit or program a text description (Name) such as "ACME Central Station" for the Telephone number press left arrow key. Spell out the text using the number keys. I.E. For a "K" press the 5 key twice. To move the cursor press the right or left arrow keys. While programming the text, pressing the Chime key inserts a space, and the Bypass key erases 1 digit. The up and down arrow keys toggles between upper and lower case. Press the ELK key when complete.

Menu 09 - Area Reporting Codes

Press RIGHT arrow key to select this menu. Press UP or DOWN arrow keys to select another menu. The ELK key backs up one menu level. To exit press the * or Exit key.

09-Area Reporting Codes

NOTE: Enter a two digit value to enable a particular report code. To disable a report code enter 00. When SIA or Contact ID is the reporting format, the two digit value can simply be 01 since the control automatically produces the correct code according to the SIA or Contact ID protocol. For 4+2 pulse format, enter a value from 01 to FF. To enter the A thru F HEX characters press the RIGHT arrow key to position the cursor under the desired digit, then press the UP arrow (shift) key once. Each press of the 2 key will now produce the following: 2, A, B, C. Each press of the 3 key will now produce the following: 3, D, E, F. Press the RIGHT arrow key to cancel shift and move to the next character. See Appendix for a summary of the SIA and Contact ID codes.

Area Report Codes

Description of Option

AR1: Sel ◀ Prg ▶
ReportCodesArea1

Each of the eight (8) Areas has specific communicator reporting codes for events that only occur within that area. Using the up/down arrow keys, select the appropriate area, then press the right arrow key to begin starting with option 01.

AR1 01:000=Sec ▶
Dialer Delay Time

Dialer Delay Time is an amount of time following an alarm during which the report may be aborted if the area is disarmed by a valid user. An optional alarm abort code may be programmed to report. Range is 000 to 255 seconds. Default is 000 (delay disabled).

AR1 02:Code= 00 ▶
Alm Abort Code

Alarm Abort code is an optional code that may be reported when an alarm is aborted during the Comm Abort Time window. Range is 00 to FF. Default is 00 (no report).

AR1 03:000=Sec ▶
CancelWindowTime

Cancel Window Time is the time following an alarm during which a cancel code will be reported if the area is disarmed. Cancel is not the same as abort since the alarm has already reported. Range is 00 to FF. Default is 00 (no report).

AR1 04:Code= 00 ▶
Alm Cancel Code

Alarm Cancel code is the code that will be reported if the area in alarm is disarmed within the Cancel Window Time. Range is 00 to FF. Default is 00 (no report).

AR1 05:Code= 00 ▶
Close Automatic

Close Automatic code will be reported anytime the area is armed automatically by a Rule from the RP software programming. Refer to the Ness-RP Rules Programming instructions. Range is 00 to FF. Default is 00 (no report).

AR1 06:Code= 00 ▶
Close Early

Close Early code will be reported if the area is closed prior to a programmed Expected Arm time. Refer to the Ness-RP Rules Programming instructions. Range is 00 to FF. Default is 00 (no report).

AR1 07:Code= 00 ▶
Close Extended

Close Extended code will be reported if a programmed Expected Arm time is extended by a valid user. Refer to the Ness-RP Rules Programming instructions. Range is 00 to FF. Default is 00 (no report).

AR1 08:Code= 00 ▶
Fail To Close

Fail to Close code will be reported if the area is not armed by a programmed Expected Arm time. Refer to the Ness-RP Rules Programming instructions. Range is 00 to FF. Default is 00 (no report).

AR1 09:Code= 00 ▶
Late Close

Late to Close code will be reported if the area is armed after a programmed Expected Arm time. Refer to the Ness-RP Rules Programming instructions. Range is 00 to FF. Default is 00 (no report).

AR1 10:Code= 00 ▶
Keyswitch Close

Keyswitch Close code will be reported in place of a user code whenever the area is armed by a keyswitch. Refer to the Ness-RP Rules Programming instructions. Range is 00 to FF. Default is 00 (no report).

Menu 09 - Area Reporting Codes (continued)

Area Report Codes

Description of Option

**AR1 11:Code= 00 ▶
Duress Code**

Duress code will be reported if the area is armed or disarmed by a valid user code that is programmed with the duress attribute. Range is 00 to FF. Default is 00 (no report).

**AR1 12:Code= 00 ▶
Open After Alarm**

Open After Alarm code will be reported whenever a valid user arrives and disarms the area following an alarm activation. Range is 00 to FF. Default is 00 (no report).

**AR1 13:Code= 00 ▶
Open Early**

Open Early code will be reported if the area is disarmed prior to a programmed Expected Disarm time. Refer to the Ness-RP Rules Programming instructions. Range is 00 to FF. Default is 00 (no report).

**AR1 14:Code= 00 ▶
Fail To Open**

Fail to Open code will be reported if the area is not disarmed by a programmed Expected Disarm time. Refer to the Ness-RP Rules Programming instructions. Range is 00 to FF. Default is 00 (no report).

**AR1 15:Code= 00 ▶
Open Late**

Open Late code will be reported if the area is disarmed after a programmed Expected Disarm time. Refer to the Ness-RP Rules Programming instructions. Range is 00 to FF. Default is 00 (no report).

**AR1 16:Code= 00 ▶
Open Keypress**

Open Keypress code will be reported in place of a user code whenever the area is disarmed by a Keypress zone. Range is 00 to FF. Default is 00 (no report).

**AR1 17:Code= 00 ▶
User Lockout**

User Lockout code will be reported if someone repeatedly enters digits (see Menu 07 - Global System Definitions, Option 12 for the maximum number of digits allowed) in an attempt to hack out a valid user code. Range is 00 to FF. Default is 00 (no report).

**AR1 18:Code= 00 ▶
Exit Error**

Exit Error Code can be used to identify an accidental alarm caused by an error while arming. Locally, it works as follows: If an exit delay rolls directly into entry delay as a result of a zone being left violated, the entry delay warning AND the siren will sound. If the control is not disarmed prior to the entry delay expiring, the communicator will report the alarm along with the Exit Error code. Range is 00 to FF. Default is 00 (no report).

**AR1 19:Code= 00 ▶
Fail Communicate**

Fail to communicate displays on the keypad and the event log when the communicator fails to complete its report using the number of dial attempts. A good communications report must occur in order to reset/clear the failure. If this fail to communicate report code is enabled, it will be reported with next good communications to indicate a "past" failure. Range is 00 to FF. Default is 00 (no report).

Based on the event, the CID (Contact ID) or SIA Codes for Area Reporting Codes will be:

Area RCs	CID	SIA	Area RCs	CID	SIA
Alarm Abort	1406	OC	Open After Alarm	1450	OR
Alarm Cancel	1406	OC	Early Open	1451	OK
Automatic Close	3403	CA	Fail To Open	1453	OI
Early Close	3451	CK	Late Open	1452	OJ
Closing Extended	1464	CE	Key Switch Open	1409	OS
Fail To Close	1454	CI	Keypad Locked Out	1461	JA
Late Close	3452	CJ	Exit Error	1457	EE
Key Switch Close	3409	CS	Fail To Communicate	1354	RT
Duress	1121	HA			

Menu 10 - Zone Reporting Codes

10-Zone Reporting Codes

Press RIGHT arrow key to select this menu. Press UP or DOWN arrow keys to select another menu. The ELK key backs up one menu level. To exit press the * or Exit key.

NOTE: Enter a two digit value to enable a report code. To disable a report code enter 00. When SIA or Contact ID is the reporting format, the two digit value can simply be 01 since the control automatically produces the correct code according to the SIA or Contact ID protocol. For 4+2 pulse format, enter a value from 01 to FF. To enter the A thru F HEX characters press the RIGHT arrow key to position the cursor under the desired digit, then press the UP arrow (shift) key once. Each press of the 2 key will now produce the following: 2, A, B, C. Each press of the 3 key will now produce the following: 3, D, E, F. Press the RIGHT arrow key to cancel shift and move to the next character. See Appendix for a summary of the SIA and Contact ID codes.

Zone Report Codes

Z001: Sel ◀ Prg ▶
[Name of Zone]

Description of Option

Each of the 208 Zones has specific communicator reporting codes for Alarm, Restore, Bypass, and Trouble. Using the up/down arrow keys, select the appropriate zone, then press the right arrow key to begin programming of that zone.

Z001:A=00 R=00 ▶
Byp=00 Tbl=00

The cursor starts at the 00 beside A (Alarm). Enter the desired two digit reporting code and press the right arrow key to advance to the R (Restore). To jump the cursor to another report without changing this one simply press the right arrow key. The next press of the right arrow key after Tbl (Trouble) will advance the screen back to the beginning of that zone. Range is 00 to FF. Default for all entries is 00 (no report).

NOTE: Each reporting code must be programmed according to the desired reporting format. However, for SIA and Contact ID formats the actual reporting digits will be produced by the control according to the type of alarm or event. The only programming required to enable reporting with the SIA and Contact ID formats is to set the programmed code to a non zero (0) value. See below:

Based on the zone definition, the CID (Contact ID) or SIA formats for Zone Reporting Codes will be:

Zone RCs	Alarms				Restore				Bypass				Trouble				
	CID	SIA	CID	SIA	CID	SIA	CID	SIA	CID	SIA	CID	SIA	CID	SIA			
01 = Burglar Entry/Exit 1	1134	BA	3134	BR	1573	BB	1370	BT	19 = Emergency Alarm	1101	QA	3101	QR	1572	QB	----	----
02 = Burglar Entry/Exit 2	1134	BA	3134	BR	1573	BB	1370	BT	20 = Freeze Alarm	1159	ZA	3159	ZR	1572	ZB	----	----
03 = Burglar Perim Inst	1131	BA	3131	BR	1573	BB	1370	BT	21 = Gas Alarm	1151	GA	3151	GR	1572	GB	----	----
04 = Burglar Interior	1132	BA	3132	BR	1573	BB	1370	BT	22 = Heat Alarm	1114	KA	3114	KR	1572	KB	----	----
05 = Burglar Int Follower	1132	BA	3132	BR	1573	BB	1370	BT	23 = Medical Alarm	1100	MA	3100	MR	1572	MB	----	----
06 = Burglar Int Night	1135	BA	3135	BR	1573	BB	1370	BT	24 = Police Alarm	1120	PA	3120	PR	1572	PB	----	----
07 = Burglar Int Nt Fillwr	1135	BA	3135	BR	1573	BB	1370	BT	25 = Police No Indication	1120	PA	3120	PR	1572	PB	----	----
08 = Burglar 24 Hour	1133	BA	3133	BR	1573	BB	1370	BT	26 = Water Alarm	1154	WA	3154	WR	1572	WB	----	----
09 = Burglar Box Tamper	1137	TA	3137	TR	1573	TB	1370	BT	27 = Key Mom Arm/Disarm	----	----	----	----	----	----	----	----
10 = Fire Alarm	1110	FA	3110	FR	1571	FB	1373	FT	28 = Key Mom Arm Away	----	----	----	----	----	----	----	----
11 = Fire Verified	1110	FA	3110	FR	1571	FB	1373	FT	29 = Key Mom Arm Stay	----	----	----	----	----	----	----	----
12 = Fire Supervisory	1200	FS	3200	FR	1571	FB	1373	FT	30 = Key Mom Disarm	----	----	----	----	----	----	----	----
13 = Aux Function 1	1150	UA	3150	UR	1572	UB	----	----	31 = Key On/Off	----	----	----	----	----	----	----	----
14 = Aux Function 2	1150	UA	3150	UR	1572	UB	----	----	32 = Mute Audibles	----	----	----	----	----	----	----	----
15 = Aux Function 3	1150	UA	3150	UR	1572	UB	----	----	33 = Analog Zone	----	----	----	----	----	----	----	----
16 = Aux Function 4	1150	UA	3150	UR	1572	UB	----	----	34 = Power Supervisory	1338	YT	----	----	----	----	1342	YP
17 = Carbon Monoxide	1162	GA	3162	GR	1572	GB	----	----	35 = Phone Key	----	----	----	----	----	----	----	----
18 = Gen Pur. Do Nothing	----	----	----	----	----	----	----	----	36 = Intercom Key	----	----	----	----	----	----	----	----

Menu 11 - Keypad F-Key Reporting Codes

11-Keypad F-Key Reporting Codes

Press RIGHT arrow key to select this menu. Press UP or DOWN arrow keys to select another menu. The ELK key backs up one menu level. To exit press the * or Exit key.

Referring back to Menu 04-Keypad Definitions, each F Key (F1 thru F6) can be programmed to activate a specific event. If the programmed "activate event" is an alarm such as: Burg, Fire, Medical, Police Panic, etc., then it is possible to have an alarm report code transmitted when an F key is used to activate that event. Enter a two digit value for the "A" alarm report code. To disable the alarm report code enter 00. If the reporting format is SIA or Contact ID, the value can simply be 01 because the control will automatically produce the correct code according to alarm type using the SIA or Contact ID protocol. For 4+2 pulse format, enter a value from 01 to FF. To enter the A thru F HEX characters press the RIGHT arrow key to position the cursor under the desired digit, then press the UP arrow (shift) key once. Each press of the 2 key will now produce the following: 2, A, B, C. Each press of the 3 key will now produce the following: 3, D, E, F. Press the RIGHT arrow key to cancel shift and move to the next character.

F-Key Report Codes

FK01: A=00 [KP01 FKey01]

Description of Option

Each Keypad has 6 programmable F keys. This menu displays the F keys starting at FK01 thru FK06 for Keypad 1, then FK07 thru FK13 for Keypad 2, etc. Use the UP and DOWN arrow keys to select the appropriate keypad and key, then press the RIGHT arrow key to programming the code. It may take some experimenting but it is possible to jump directly to a specific keypad and key by entering a two digit number.

To program the alarm report code press the RIGHT arrow key to move the cursor into the A= column, then enter a two digit value. Range is 00 to FF. Default is 00 (no report). To return back to the left column to select another key or keypad press the ELK key

FK02:A=00 [KP01 FKey02]

NOTE: Each reporting code must be programmed according to the desired reporting format. However, for SIA and Contact ID formats the actual reporting digits will be produced by the control according to the type of alarm or event. The only programming required to enable reporting with the SIA and Contact ID formats is to set the programmed code to a non zero (0) value. See below:

Based on the F Key Event definition, the CID (Contact ID) or SIA formats will be:

Alarms		Alarms	
Keypad Alarm RCs	CID SIA	Keypad Alarm RCs	CID SIA
00 = Disabled	---- ----	18 = Emergency Alarm	1101 QA
01 = Burglar Entry/Exit 1	1134 BA	19 = Freeze Alarm	1159 ZA
02 = Burglar Entry/Exit 2	1134 BA	20 = Gas Alarm	1151 GA
03 = Burglar Perim Inst	1131 BA	21 = Heat Alarm	1114 KA
04 = Burglar Interior	1132 BA	22 = Medical Alarm	1100 MA
05 = Burglar Int Follower	1132 BA	23 = Police Alarm	1120 PA
06 = Burglar Int Night	1135 BA	24 = Police No Indication	1120 PA
07 = Burglar Int Nt Delay	1135 BA	25 = Water Alarm	1154 WA
08 = Burglar 24 Hour	1133 BA	26 = Key Mom Arm/Disarm	---- ----
09 = Burglar Box Tamper	1137 TA	27 = Key Mom Arm Away	---- ----
10 = Fire Alarm	1110 FA	28 = Key Mom Arm Stay	---- ----
11 = Fire Verified	1110 FA	29 = Key Mom Disarm	---- ----
12 = Fire Supervisory	1200 FS	30 = Key On/Off	---- ----
13 = Aux1 24hr Alarm	1150 UA	31 = Mute Audibles	---- ----
14 = Aux2 24hr Alarm	1150 UA	32 = Power Supervisory	1338 YT
15 = Keyfob	---- ----	33 = Temperature	---- ----
16 = Non-Alarm	---- ----	34 = Analog	---- ----
17 = Carbon Monoxide	1162 GA		

Menu 12 - Sys Report Code Options & Codes

Press RIGHT arrow key to select this menu. Press UP or DOWN arrow keys to select another menu. The ELK key backs up one menu level. To exit press the * or Exit key.

12-Sys Rpt Code ▶ Options & Codes

System Report Codes and Options are global to the entire system such as Low Battery, AC Fail, etc. Using the up/down arrow keys, select the appropriate option, then press the right arrow key to begin programming that option.

NOTE: Enter a two digit value to enable a report code. To disable a report code enter 00. When SIA or Contact ID is the reporting format, the two digit value can simply be 01 since the control automatically produces the correct code according to the SIA or Contact ID protocol. For 4+2 pulse format, enter a value from 01 to FF. To enter the A thru F HEX characters press the RIGHT arrow key to position the cursor under the desired digit, then press the UP arrow (shift) key once. Each press of the 2 key will now produce the following: 2, A, B, C. Each press of the 3 key will now produce the following: 3, D, E, F. Press the RIGHT arrow key to cancel shift and move to the next character. See Appendix for a summary of the SIA and Contact ID codes.

Sys Rpt Code Options

Description of Option

**SR01: 015=AC Fail
Rpt Delay - Min ▶**

AC Fail Report Delay may be set to delay from 001 to 255 minutes. Valid range is 000 - 254 minutes. Default setting is 15 minutes. Setting this location to 255 results in no AC failure annunciation at the keypad or by the dialer.

**SR02: T=00 R=00 ▶
AC Fail Codes**

AC Fail T (Trouble) code will be reported upon AC failure, after any AC Fail Rpt delay time. AC Fail R (Restore) will be reported immediately upon restoration of the AC power. Range is 00 to FF. Default is 00 (no report).

**SR03: 00 = Auto ▶
Test Code**

Auto Test code may be periodically reported to verify that the telephone line and internal communications circuitry is functioning properly. Range is 00 to FF. Default is 00 (no report).

**SR04: =00:00 ▶
Auto Test Hr:Min**

Auto Test Hr:Min is normally set to occur during off-peak times. However, it may be set to occur at any specific hour and minute. This location requires military time format. IE: 7:30 is AM while 19:30 is 7:30pm. Default is 00:00 which is Midnight.

**SR05: 000=Days ▶
Between AutoTest**

Days Between Auto Test may be set to skip a certain number of days, from 1 to 255. The default value is 000 which means that the test code, if programmed, will be reported every day (24 hour interval) from the Auto Test time.

**SR06: T=00 R=00 ▶
Aux Overcurrent**

Aux. Overcurrent trouble (T) will be reported when the control's auxiliary power is overloaded. A restore (R) will be reported when the overload ceases. Range is 00 to FF. Default is 00 (no report).

**SR07: T=00 R=00 ▶
Exp Module Tbl**

Exp Module Tbl T (Trouble) will be reported when an enrolled data bus module fails to respond or is missing. Exp Module Tbl R (Restore) will be reported when the module is restored. Range is 00 to FF. Default is 00 (no report).

**SR08: 00=Instal ▶
Program Begin**

This report code may be programmed in order to know when the Installer Level of Programming has been entered. Range is 00 to FF. Default is 00 (no report).

**SR09: 00=Instal ▶
Program End**

This report code may be programmed to notify when Installer Level Programming is ended. To prevent unnecessary reports, the report will not transmit until the * key is pressed three times to signify final end of programming. The report will occur automatically at Midnight if the * key sequence is not pressed. Range is 00 to FF. Default is 00 (no report).

**SR10: 00= Log ▶
80% Full**

Log 80% Full will be reported whenever the Event Log becomes 80% full. Range is 00 to FF. Default is 00 (no report). The Ness-RP is required to download the log and/or clear it.

Menu 12 - Sys Report Code Options & Codes (continued)

Sys Rpt Code Options

Description of Option

SR11: T=00 R=00 ▶
Low Battery

Low Battery T (Trouble) will be reported if the battery drops below 11.2 Volts. Low Battery R (Restore) will be eligible to report once the battery has passed a test at 11.5 Volts or higher. Range is 00 to FF. Default is 00 (no report).

SR12: T=00 R=00 ▶
Memory Error

Memory Error T (Trouble) will be reported if the system memory checksum fails. An upload or review of the programming is the only way to detect where the error occurred. To clear the error and send a R (Restore) you must enter and exit the installer programming mode. Range is 00 to FF. Default is 00 (no report).

SR13: 00= Up/
Download End ▶

Up/Download End will be reported upon completion of a Up/Download session as a verification that the control was accessed. Range is 00 to FF. Default is 00 (no report).

SR14: T=00 R=00 ▶
Phone Line Fault

Phone Line Fault T (Trouble) will be reported if the Voltage and Current is lost on the telephone line. Phone Line Fault R (Restore) will report upon restoral of the telephone line. Range is 00 to FF. Default is 00 (no report).

SR15: T=00 R=00 ▶
Output 2 Trouble

Output 2 T (Trouble) will be reported if an open circuit occurs on Output 2. Output 2 R (Restore) will be reported upon restoral of the connection. Range is 00 to FF. Default is 00 (no report).

Based on the event, the CID (Contact ID) or SIA Codes for System Reporting Codes will be:

System RCs	CID	SIA	System RCs	CID	SIA
AC Fail	1301	AT	Log 80% Full	1623	JL
AC Restore	3301	AR	Low Backup Battery	1302	YT
Automatic Test	1602	R P	Low Battery Restore	3302	YR
Aux Over Current	1312	Y P	Memory Error	1304	YF
Aux Over Current Restore	3312	Y Q	Remote Programming End	1412	R S
Expansion Module Trouble	1333	E T	Telephone Line Fault	1351	L T
Expansion Module Restore	3333	E R	Telephone Line Restore	3351	L R
Local Programming Begin	1627	L B	Output 2 Trouble	1322	YA
Local Programming End	1628	L X	Output 2 Restore	3322	Y H

Menu 13 - User Report Codes



Press RIGHT arrow key to select this menu. Press UP or DOWN arrow keys to select another menu. The ELK key backs up one menu level. To exit press the * or Exit key.

NOTE: Enter a two digit value to enable a report code. To disable a report code enter 00. When SIA or Contact ID is the reporting format, the two digit value can simply be 01 since the control automatically produces the correct code according to the SIA or Contact ID protocol. For 4+2 pulse format, enter a value from 01 to FF. To enter the A thru F HEX characters press the RIGHT arrow key to position the cursor under the desired digit, then press the UP arrow (shift) key once. Each press of the 2 key will now produce the following: 2, A, B, C. Each press of the 3 key will now produce the following: 3, D, E, F. Press the RIGHT arrow key to cancel shift and move to the next character. See Appendix for a summary of the SIA and Contact ID codes.

User Report Codes

Description of Option

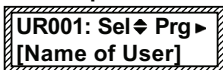

Each of the 99 User Codes and the Installer has communicator reporting codes for Open (disarm) and Close (arm). Using the up/down arrow keys, select the appropriate user, then press the right arrow key to begin programming of that user's report codes.

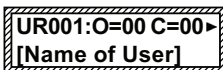

The cursor starts at the 00 beside O (Open). Enter the desired two digit reporting code and press the right arrow key to advance to the C (Close). Range is 00 to FF. Default is 00 (no report). To jump the cursor to the next report code without changing this one simply press the right arrow key. The next press of the right arrow key will advance back to the beginning screen.

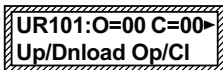
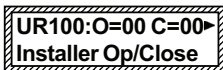

The CID (Contact ID) or SIA Codes for User Reporting Codes are:

User RCs	CID	SIA
Open	1401	OP
Close	3401	CL

Menu 14 - Wireless Definitions



For details refer to the Ness M1 Radio Receiver Manual.

[Intentionally left blank]

Section 4 - PC Programming and Automation Capabilities

4.1 Ness-RP Software

Ness-RP (RP) is a Windows based software package that is compatible with Windows 95 and later. It features an extremely intuitive user interface and contains all data in a central database. RP can be run on a single PC or over a local area network (LAN) with multiple operators. In addition to the traditional security programming features, RP allows you to create and manage the automation functionality in the M1 control. The following information is a brief overview including illustrations of the various screens. Please refer to RP's on-line help file for specific operation details.

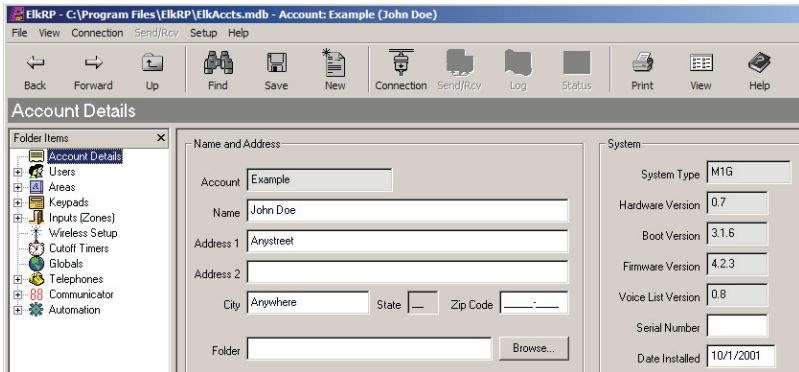

4.1.1 RP Connection Methods

There are 3 methods for the RP software to connect with the M1 control. Regardless of the method, the control's serial number and RP access code **MUST** match in order for the connection to be successful. The connection methods are:

1. **Direct using Com_ (PC COM port)** - Requires a 9 pin serial cable from the PC's RS-232 COM port to the M1's on-board 9 pin serial port. Data transfer is 115,200 baud. **NOTE: If your computer only has a USB port, an approved converter (USB to RS-232) is available from Ness (Ness part # 101-231).**

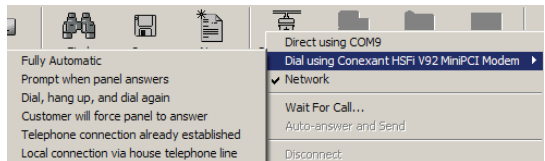

2. **Dial-up using Modem** and phone line - RP is compatible with virtually all computer modems, even 56k modems. This is due to the M1's built-in V.22 bis "True" modem, which handles data transfer at 2,400 baud. The 6 dial-up options are:
 - Fully Automatic - RP dials the control phone number and listens for the control to answer on it's "rings until answer" setting. If an answering machine answers, RP will transmit codes to override it automatically.
 - Prompt when answer - RP dials and listens for the control to answer. It waits for a manual OK before connecting.
 - Dial, hang up, dial again - This is faster than waiting on the control's "rings until answer" setting. It is also useful for reaching premises that have telephone company answer/forward services. The M1 must be enabled for this option. After dialing, RP leaves the PC speaker on, and prompts you to click "Hang-up" after you hear two rings. It then forces a time delay before allowing you to click OK to start the second dial. As long as the control properly detects the first two rings and subsequent hang-up, it will wait up to 45 seconds for a second call and answer that call on the first ring.
 - Customer will force answer - Similar to method 1 except the User must enter keypad menu 8, option 5, item 1 to force the control to answer. This is necessary if the "rings until answer" or "dial/hang-up/dial" options are not programmed.
 - Telephone connection already established - If a voice connection is already established using the control's phone line and the PC's phone line, this method can be used to take over the connection and initiate an immediate connection.
 - Local connection via house telephone line - Convenient way to connect locally from virtually any house phone jack that is on the same phone line as the one attached to the control. Connect the PC modem to the phone wall jack, click on Local Connection, and RP will pick up the line and enter the access codes required to connect with the control.
3. **Network** - With an optional M1XEP Ethernet Port module (Ness part # 101-215) you can connect over a Local or Wide Area Network. (Contact Ness for details)

4.1.2 Check for Conflicts

During the connect and disconnect process RP performs an automatic check of the data stored in the control and compares it to the database. If there are any conflicts (differences), a pop-up resolution window display them and allows corrections to be made. ELK regards "Check for Conflicts" to be an especially important feature. It can point out any changes that have occurred such as a user having added or changed a code. The resolution window allows you to receive the control's data into the database (accept the local version) or send the RP data to the control (accept the database version). **NOTE: Checking for conflicts adds considerable time to the connect/disconnect process, especially on dial-up connections. For this reason, the automatic check for conflicts may be disabled from the SETUP menu. A manual Check for Conflicts can be selected from the Send/Rcv icon.**

4.1.3 Sending and Receiving Data

RP allows many options and groups of options to be sent or received individually, which greatly reduces the on-line connect time if there are only a few items to be changed. However, a full send or receive occurs very quickly, thanks to the M1's built-in V.22 bis "True" Modem. RP features easy to use menus & toolbar icons and makes extensive use of the right mouse button to perform operations. Try right clicking on any item or icon to see the available options.

4.2 Update/Verify Firmware in the Control and Peripherals

The M1 stores it's operating firmware in "Flash" memory. This state-of-the-art memory allows electronic field updates to the control and its peripherals, and eliminates the old fashion method of changing IC chips or shipping boards back to the factory. As new firmware updates become available, they will be posted on Ness's website [www.ness.com.au/m1] in a password restricted "M1 Dealers ONLY" location. **NOTE: Firmware updating can only be done from a Direct to PC Com port connection or an optional Ethernet Network connection. Due to the amount of data that has to be transferred, Dial-up connections cannot be used to perform firmware updates.**

How to Update Firmware:

1. Connect a 9 pin serial cable from the Computer's Serial Port to the 9 Pin RS232 Connector on the M1.
2. Start RP and open the account belonging to that particular M1 control. Click on the Connection menu icon and establish a connection using the **Direct using Com_** option.
3. Click on Update/Verify Firmware from the Send/Rcv menu icon.
4. On the Update/Verify screen, select the device to be updated (Control, Keypad, etc.) along with the "Update to new firmware" option. Then click Continue.
5. The Update Firmware screen displays the device name, the current Firmware, Hardware, and Bootware version, and a pull down window for selecting the firmware version to use on the update. Always select the latest firmware version (highest number). Be sure to save all update (.bin) files that are downloaded or received via CDROM into the ~Program Files\NessRP\Updates directory on your computer. This is where RP looks for all update files.
6. Click on the check box for "Update". If "Reprogram" or "Rollback" is displayed the firmware file is the same as OR older that what is in the control. Reprogramming with the same firmware is a waste of time but was included for factory testing purposes. Rollback is not recommended except under the guidance of Ness Technical Support.

NOTE: The option for "Verify existing firmware" on the Update/Verify screen is normally not required except for factory diagnostics. If the control has multiple keypads, expanders, etc., RP will display the details about each one onscreen with a check box for selecting units for updating.

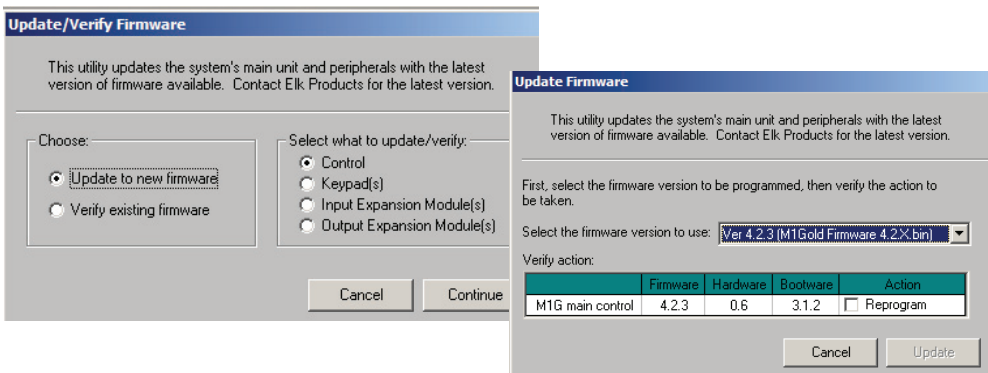

4.3 Automation Rules and Attributes

The Ness-M1, together with the RP Automation Programming software offers powerful, easy to setup and manage, life style enhancement features. The automation programming allows mixing and matching of lighting components, outputs (relays or voltage), thermostats, temperature sensors, and all the security inputs and features to integrate functions that add value and appeal to the owner/user. Lights can be set to turn on and off in response to a time or day, a certain sensor, or according to the arm/disarm status of the security control. Outputs can be set to control door strikes, irrigation sprinklers, circulating pumps valves, etc.

The power behind the automation features is the unique RULES Engine. Rules are expressions of what you would like to happen at a given time or in response to a set of circumstances. The following information is intended to provide an overview of the vast automation features in the M1. **NOTE: The quantities and capabilities of the automation and rules programming will vary based on the model of M1 that is being programmed. For example: The standard M1 supports 100 rules and limited lighting options while the M1G (Gold edition) supports 528 rules and extensive lighting options and capabilities. Some examples in this section may not be available with the standard M1.**

TASKS - A Task is similar to a computer macro, in that a single activation can result in multiple actions or events. **The actions and triggering of a Task must be written or developed in a Whenever/And/Then Rule.** The purpose of the task screen is to assign each task its own 16 character description, 6 word voice phrase, and the ability to "Show" on the keypad or the telephone remote control menu. Up to 32 Tasks can be programmed. Examples are "Water the Lawn" which could be used to turn on a series of outputs or relays to control underground water valves for a certain time duration. "Welcome Home" could be task used to control a series of lights at a given time or day or in response to someone disarming the security system. The following shows several tasks and the voice description word listing.

Task	Name	Show	Voice Description
1	Wake-Up	X	Wake up Time
2	Entertainment	X	Entertainment
3	Flood Lights	X	Flood Lights
4	Water the Yard	X	Water The Yard
5	Welcome Home	X	Welcome Home
6			
7			
8			
9			
10			
11			
12			
13			
14			

LIGHTING - The M1 can control up to 256 Light (or appliance) devices. Each is assigned to one of 256 addresses. Each device is displayed in columnar format with the following options and settings: **Name** - Each device can be given a 16 character name (description) which is displayed on the keypad when the light is being controlled. **Format** - This pull down box selects the protocol of the device. Depending on the M1 model you have, the available Lighting formats are: Standard, Extended, Preset dim, Compose, Serial Port. The Serial port format is for UPB, ALC, Centralite, others through an ELK-M1XSP Lighting/Thermostat/Serial Expander Interface. **Type** - This pull down box selects the whether the device is a: On/Off Switch, Dimmer, or Appliance. **Show** - If this box is checked the device will appear "show" on the keypad and telephone remote as you scroll through the automation control menus. **2-way** - This checkbox is used to record whether the device is capable of replying back to commands. **Voice Description** - Click on this box to pop up a window for programming a custom 6 word voice phrase. The voice is used primarily during a telephone remote session. **NOTE: Additional lighting formats are in development, including the new Z-Wave wireless devices. Even if a lighting product is not directly supported, it is always possible to use RS-232 ASCII strings for communicating lighting control.**

Message	Word 1	Word 2	Word 3	Word 4	Word 5	Word 6
AC Power Failure (vm210)	AC power	Fail	(Blank)	(Blank)	(Blank)	(Blank)
Telephone Line Trouble (vm211)	Telephone	Line	[200ms Silence]	(Blank)	(Blank)	(Blank)
Audio Module Missing (vm224)	Audio	Module	Missing	(Blank)	(Blank)	(Blank)
Input Expander Missing (vm227)	Input	Expander	Missing	(Blank)	(Blank)	(Blank)
Keypad Missing (vm228)	Keypad	Missing	(Blank)	(Blank)	(Blank)	(Blank)
Output Expander Missing (vm230)	Output	Expander	Missing	(Blank)	(Blank)	(Blank)
System Battery Is Low (vm234)	System	Battery	Is low	[200ms Silence]	(Blank)	(Blank)
Output 2 Speaker Missing (vm323)	Output	Two	Speaker	Missing	(Blank)	(Blank)

OUTPUTS - These can be in the form of voltage only, relays, or a combination of the two. Depending on the M1 model, up to 208 outputs may be controlled. The first 32 outputs have a 16 character description, 6 word voice phrase, and the "Show" on keypad or telephone remote option. However, any output may be controlled from the keypad or telephone remote by entering its number. Outputs can be used to actuate door locks, motors, fan, pumps, etc.

Output	Name	Show	Voice Description
9	Air Cond	X	Air Condition
10	Door Lock	X	Main Entry Door Lock
11	Output 011		

SUNRISE/SUNSET - Sunrise and sunset can be used to control lighting and other entities. This section is the setup for the M1's built-in Astronomical clock, which is capable of calculating sunrise and sunset times automatically. The inputs necessary to setup the M1 for sunrise/sunset are latitude, longitude, and the time zone value where the M1 is installed. Latitude/longitude information can often be found printed on city or state highway maps, or it can be researched on the internet. (e.g. http://www.bcca.org/misc/qiblib/latlong_oc.html#AUSTRALIA) After entering the required information, click calculate and then send to the M1.

Latitude: 37 Degrees 49 Minutes	North <input checked="" type="checkbox"/> North <input type="checkbox"/> South															
Longitude: 144 Degrees 58 Minutes	West <input checked="" type="checkbox"/> West <input type="checkbox"/> East															
Time Zone: +10 Eastern Australia / Eastern Russia / Guam Time																
<input type="button" value="Calculate"/>																
Click to calculate all sunrise and sunset times based on the latitude and longitude entered above.																
Sunrise/sunset times listed above have been calculated based on latitude, longitude, and time zone values entered.																
All times are Standard Time. If Daylight Savings Time is observed, the control will adjust for it automatically by adding one hour to the displayed times below.																
	<table border="1"> <thead> <tr> <th></th> <th>Sunrise</th> <th>Sunset</th> </tr> </thead> <tbody> <tr> <td>January 1</td> <td>05:01 AM</td> <td>07:45 PM</td> </tr> <tr> <td>2</td> <td>05:02 AM</td> <td>07:45 PM</td> </tr> <tr> <td>3</td> <td>05:03 AM</td> <td>07:45 PM</td> </tr> <tr> <td>4</td> <td>05:04 AM</td> <td>07:45 PM</td> </tr> </tbody> </table>		Sunrise	Sunset	January 1	05:01 AM	07:45 PM	2	05:02 AM	07:45 PM	3	05:03 AM	07:45 PM	4	05:04 AM	07:45 PM
	Sunrise	Sunset														
January 1	05:01 AM	07:45 PM														
2	05:02 AM	07:45 PM														
3	05:03 AM	07:45 PM														
4	05:04 AM	07:45 PM														

NOTE: The Time Zone automatically assumes "standard time". Therefore, the calculated times will reflect standard time. If the control is set for "Observe Daylight Savings Time" the sunrise/sunset times will be adjusted by the control accordingly.

VOICE - This section is used to setup and customize many of the 6 word phrases that can be spoken by the control during a certain event or when commanded by an automation rule. The capabilities of this section are quite powerful. The library contains over 500+ words in addition to specialized speech commands for inserting conditions, current time, status/state, time delays, and even an 800hz tone. In addition, any of the 10 custom recordable messages can be included when building these 6 word phrases.

Message	Word 1	Word 2	Word 3	Word 4	Word 5	Word 6
AC Power Failure (vm210)	AC power	Fail	{Blank}	{Blank}	{Blank}	{Blank}
Telephone Line Trouble (vm211)	Telephone	Line	{200ms Silence}	{Blank}	{Blank}	{Blank}
Audio Module Missing (vm224)	Audio	Module	Missing	{Blank}	{Blank}	{Blank}
Input Expander Missing (vm227)	Input	Expander	Missing	{Blank}	{Blank}	{Blank}
Keypad Missing (vm228)	Keypad	Missing	{Blank}	{Blank}	{Blank}	{Blank}
Output Expander Missing (vm230)	Output	Expander	Missing	{Blank}	{Blank}	{Blank}
System Battery Is Low (vm234)	System	Battery	Is low	{200ms Silence}	{Blank}	{Blank}
Output 2 Speaker Missing (vm323)	Output	Two	Speaker	Missing	{Blank}	{Blank}

CUSTOM SETTINGS - These are 20 memory locations which may be assigned a 12 character description, a function type (one of 3), and a starting value. An authorized user can then access the custom settings from keypad user menu 7-Automation Custom Settings, and modify the value whether it be a numeric value, a timer (seconds), or a time-of-day. Incorporating custom settings in rules provides the user the ability to modify how the rule will operate. For instance, the user can modify the time or duration for the lawn sprinklers which have been programmed to turn on automatically. The function types include: A 5 digit raw number with a range of 00000 to 65,535, a 5 digit timer (seconds) with a range of 00000 to 65,535 seconds, or a Time (time of day) which is formatted as 00:00 with a range of 00:00 to 23:59.

Custom Setting	Name	Type	Value
1	Water On Tm	1 = Timer	0
2		0 = Number	0
3		0 = Number	0
4		0 = Number	0

COUNTERS - These memory locations (often called flags) can be set, incremented, decremented, or compared by an automation rule to track an event or keep up with how many times an event has occurred. There are a total of 64 counters. Each can be programmed with a 12 character description, making it easy to reference in an automation rule.

Counter	Name
1	Memory01
2	Memory02
3	Memory03

THERMOSTATS - HVAC Thermostats may be read and/or controlled by the M1 and its automation rules engine. This menu allows each thermostat to be assigned a 12 character description for easy reference in an automation rule. The M1 is currently compatible with the following communicating thermostats: RCS, Aprilaire, and HAI. Due to the various data protocols, a Lighting/Thermostat/Serial Interface Expander (M1XSP-ness part # 101-214) is needed to couple the M1 data bus to HVAC thermostats. Depending on the brand of thermostat, its wiring interface (RS-232 or RS-485), and the model of M1 that you are installing, up to 16 HVAC thermostats can be controlled. Many communicating thermostats operate stand-alone when they are not being remotely commanded by an automation controller.

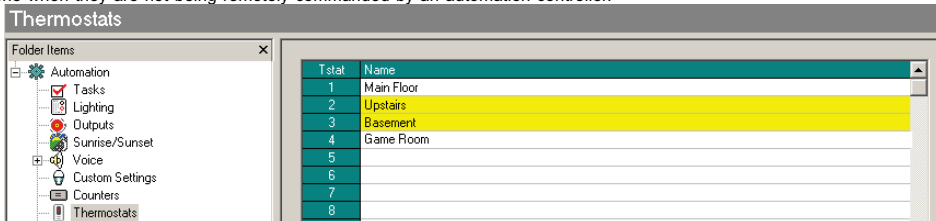

TEXTS - This section allows custom text messages to be constructed and formatted. These messages can be transmitted to an LCD keypad or out of one of the RS232 serial ports to a PC or some other type of equipment. I.E. Touchscreen, Lighting centers, etc. A message to the keypad could be "Happy Birthday" or "Please Pay Your Bill", while a message going out a serial port might be a series of ASCII characters formatted to a certain manufacturers protocol. Special options built into this menu include: automatic display of temperature readings from Zone Temperature Sensors (Ness-M1ZTS part #101-229 & 101-230) and from the temperature sensor built into an LCD Keypad. The sending or receiving of text messages is controlled by the automation rules engine. **NOTE: Text messages share the same memory space as rules. The total number of text messages and rules is limited by the M1 model that you are installing.**

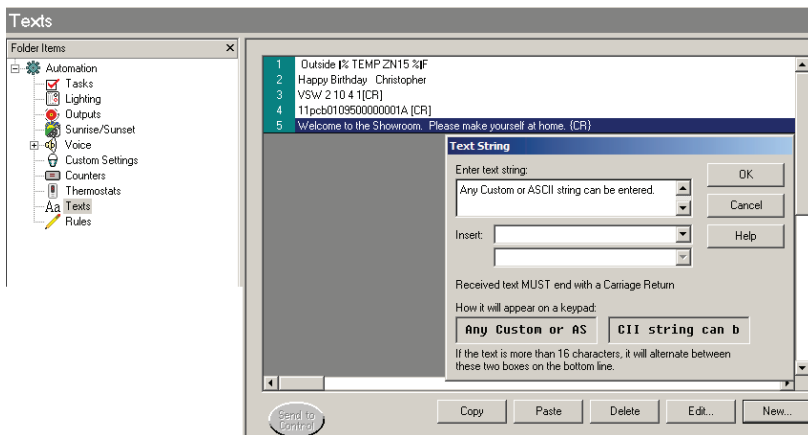

RULES - This section essentially brings all the power of the M1's automation and its features together. Rules consist of three major elements: A WHENEVER ("triggering") condition, one or more ANDs ("qualifiers"), and one or more THENs ("activations"). Rules utilize the various elements of the previously described sections in addition to the many control conditions (arm, disarm, alarms, etc.), plus many of the event codes listed in Appendix A. For example: A rule might be triggered by a Task to activate a specific light and output, but only if the control is armed in a specific mode.

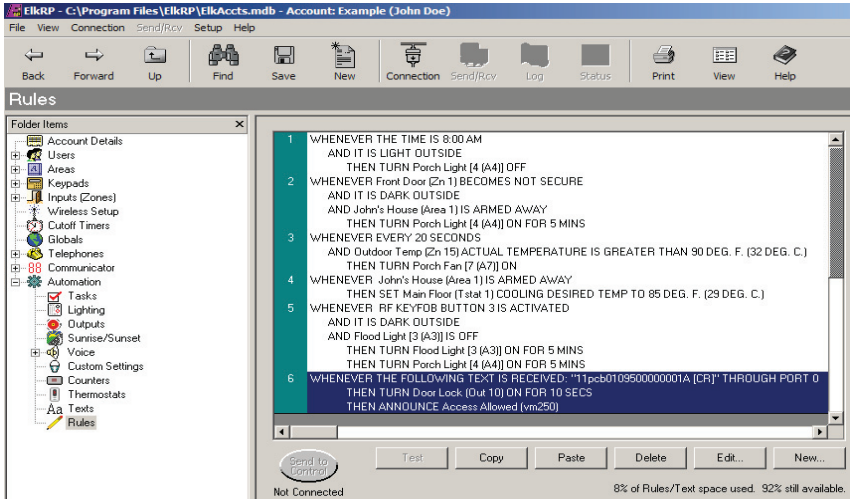

WHENEVER - The first element of a rule and the starting point of every rule is a triggering event. Every rule must have a triggering event in order to be started. A triggering event can be a time of day occurrence, a zone opening or closing, the security system going from armed to disarmed, a light changing from on to off, or literally hundreds of other events. Below are some examples of WHENEVER elements:

- Example 1 = WHENEVER THE TIME IS 08:00AM
- Example 2 = WHENEVER Living Rm Light [6 (A6)] IS TURNED ON

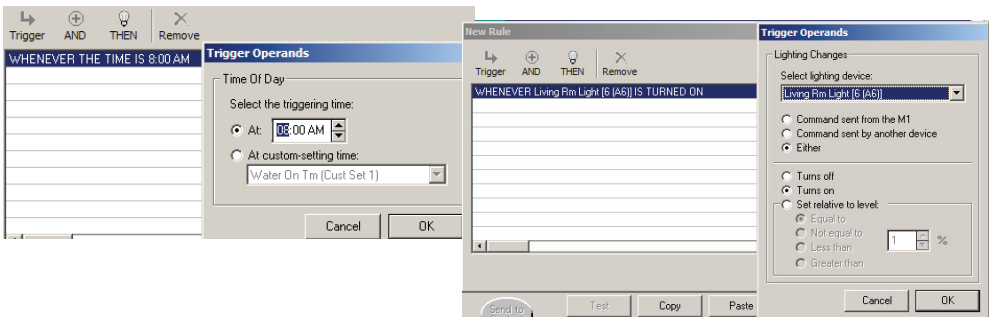

An important point to remember is that a WHENEVER gets triggered by the transition of its event from one state to another. In example 1, the trigger occurs when the time of day goes from 07:59AM to 08:00AM. In example 2, the trigger occurs when the living room light goes from off to on. Some WHENEVER elements may even include the word "BECOMES", which clearly implies that the event has to change from its current condition and "become" the alternate condition. Just remember, a rule can only be triggered by the transition of an event from one condition to another.

AND - The second and optional element of a rule is a qualifier. Rules can have one or more qualifiers OR none at all. Even though qualifiers are not required, they are ideal for filtering out actions that should not occur under certain circumstances. A qualifier can be a time, day(s), the state of light or dark, the state of a zone, output, or light, and hundreds of other variables. The state of light or dark can be determined by the Sunrise/Sunset settings from the M1's Astronomical Clock. Below are some examples of AND (qualifiers):

- Example 3 = AND Front Door (Zn 1) IS NOT SECURE
- Example 4 = AND THE DAY(S) OF THE WEEK IS/ARE -M-W-F-
- Example 5 = AND IT IS DARK OUTSIDE
- Example 6 = AND John's House (Area 1) IS ARMED AWAY

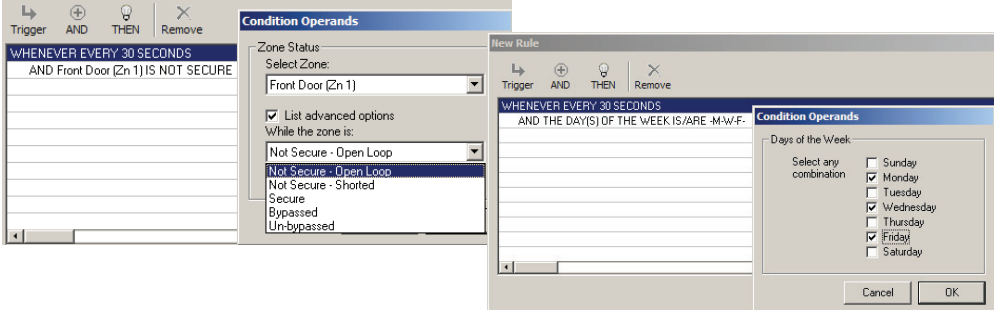

THEN - The third and final element of a rule is the action that you wish to occur as a result of the Rule being triggered and all the qualifiers being true. Below are some examples of THEN actions:

- Example 7 = THEN TURN Air Cond (Out 9) OFF
- Example 8 = THEN TURN Living Rm Light [6 A6]] OFF
- Example 9 = THEN SET Main Floor (Tstat 1) OFF
- Example 10 = THEN TURN All Lights On

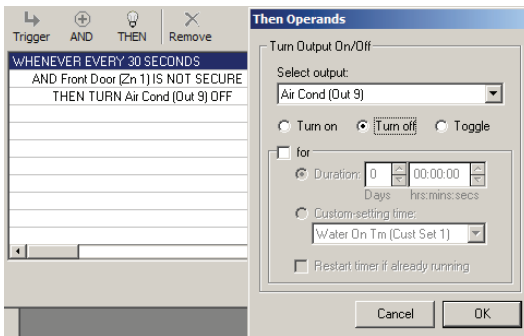

Here is an example of a rule used to turn off the air condition anytime the front door is left open by the kids. It consists of a 30 second timer for the WHENEVER trigger an AND to test the door's open/closed state, and a THEN to turn off the output that controls the air condition.

```
WHENEVER EVERY 30 SECONDS
AND Front Door (Zn 1) IS NOT SECURE
THEN TURN Air Cond (Out 9) OFF
```

Examples of Rules - Shown below are a series of rules that should help illustrate the power and results that rules can provide. Look closely at the ones that have multiple ANDs and THENs. Rules with Multiple ANDs and THENs work as follows: When the WHENEVER element is triggered, each one of the AND elements is evaluated to determine if the condition its testing is true. If any one of the ANDs are not true, the rule engine stops executing the rule immediately. However, if all ANDs are true then the rule engine moves on to the THEN elements, executing each one of them.

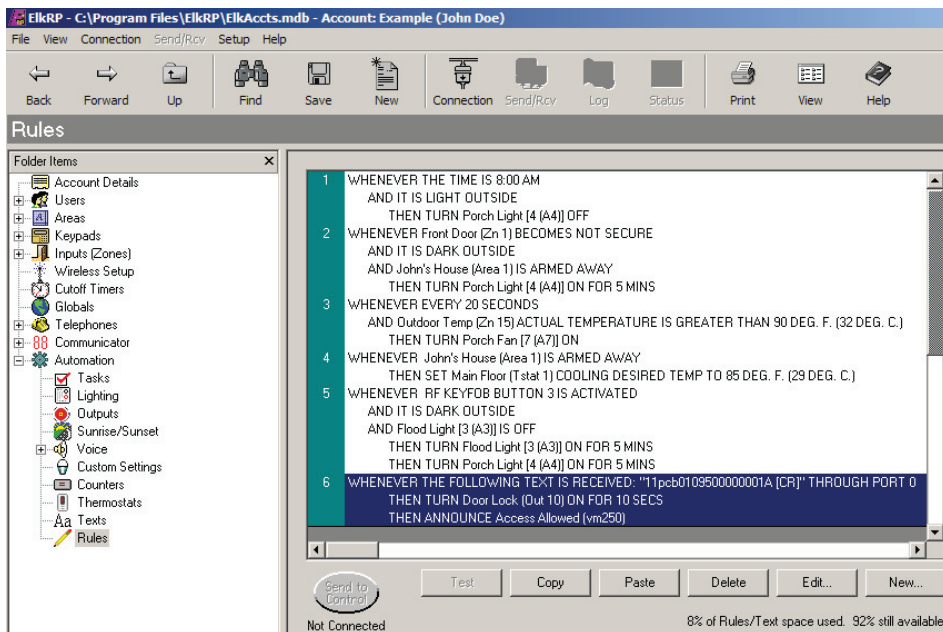

- Rule 1 is an energy saving example. It automatically turns off the Porch lights at 8:00AM everyday if it is light outside.
- Rule 2 is a courtesy light example. It will turn on the Porch light for 5 minutes when the Front door opens (exiting the building) provided it is dark outside and the control has been armed to the away mode.
- Rule 3 is a comfort example. It periodically (every 20 seconds) checks the temperature reading of the Outdoor Temp sensor and turns on the Porch Fan if the temperature becomes greater than 32 degrees. **NOTE: An additional AND element could be added to prevent the fan from operating on certain days or at certain times.**
- Rule 4 is another energy savings example. It adjusts the cooling setpoint of the Main Floor Thermostat to 29 degrees whenever the control is armed to the away mode.
- Rule 5 is especially great for a homeowner arriving home after dark. If they are equipped with an RF (wireless) Keyfob and they press button #3, the rule will turn on the outside Flood lights and Porch lights for 5 minutes, provided it is dark outside and the Flood lights are not already on. If the Floodlights were already on the rule would stop. This prevents the lights from going off after 5 minutes if you intentionally had already turned them on manually.
- Rule 6 shows how an ASCII string coming in from the serial port (port 0) could be used to unlock a door strike for 10 seconds and announce "Access Allowed". This string could come from Access Control system.

In this last example, three rules are used to chirp the outside siren based on the input of a RF Keyfob to arm the control.

- Rule 8 makes the siren chirp once if the control successfully arms when the user presses button 1.
- Rule 9 makes the siren chirp twice if the control disarms when the user presses button 2
- Rule 10 makes the siren chirp four times (error tone) if the control fails to arm when the user presses button 1.

- ```

8 WHENEVER RF KEYFOB BUTTON 1 IS ACTIVATED
 AND John's House (Area 1) IS ARMED AWAY
 THEN CHIRP THE OUTSIDE SIREN 1 TIME
9 WHENEVER RF KEYFOB BUTTON 2 IS ACTIVATED
 AND John's House (Area 1) ARM STATE = DISARMED
 THEN CHIRP THE OUTSIDE SIREN 2 TIMES
10 WHENEVER RF KEYFOB BUTTON 1 IS ACTIVATED
 AND John's House (Area 1) ARM STATE = DISARMED
 THEN CHIRP THE OUTSIDE SIREN 4 TIMES

```

# Appendix A - Event Codes

Event Codes are four digit numbers used to represent alarms, troubles, arm/disarms, restores, and various other conditions that occur within the control. For the most part, they are used only internally by the control's software. For example: turning on the alarm output. However, there are cases where the installer may need these codes. Case #1 - Keypad F key programming. Each of the Keypad F keys may be programmed to activate a particular condition such as Emergency Panic Alarm. See Menu 04 - Keypad Definitions. The activation event code can be any of the zone definition codes. The F1 key may also be programmed to light up or "illuminate" when a condition is active. The F1 key can illuminate when the Emergency Panic Alarm is active by programming the four digit event code 1011 = Emergency Alarm. Case #2 - Event History log. Each of the 512 entries in the event history log is represented by one of these 4 digits event codes, along with the time, date, area, and/or user code. It may be necessary or helpful to have these codes handy to fully interpret the log.

| Event                          | Description | Reset                          | Event                          | Description                         | Reset                         | Event                                | Description                 | Reset | Event | Description | Reset |
|--------------------------------|-------------|--------------------------------|--------------------------------|-------------------------------------|-------------------------------|--------------------------------------|-----------------------------|-------|-------|-------------|-------|
| 0000 or 1000 = No Event        |             | N                              | 1063 = Emergency Alm in Area 1 | TMC                                 | 1128 = Fire Trouble, Any Zone | TMC                                  | 1191 = Area 1 is Armed Stay | N     |       |             |       |
| 1001 = Fire Alarm              | TMC         | 1064 = Emergency Alm in Area 2 | TMC                            | 1129 = Burglar Trouble, Any Zone    | TMC                           | 1192 = Area 2 is Armed Stay          | N                           |       |       |             |       |
| 1002 = Fire Supervisory        | TMC         | 1065 = Emergency Alm in Area 3 | TMC                            | 1130 = Fail to Communicate Tbl      | N                             | 1193 = Area 3 is Armed Stay          | N                           |       |       |             |       |
| 1003 = Burglar Alarm, Any Area | TMCB        | 1066 = Emergency Alm in Area 4 | TMC                            | 1131 = RF Sensor Low Battery Tbl    | N                             | 1194 = Area 4 is Armed Stay          | N                           |       |       |             |       |
| 1004 = Medical Alarm, Any Area | TMC         | 1067 = Emergency Alm in Area 5 | TMC                            | 1132 = Lost ANC Module Trouble      | N                             | 1195 = Area 5 is Armed Stay          | N                           |       |       |             |       |
| 1005 = Police Alarm, Any Area  | TMC         | 1068 = Emergency Alm in Area 6 | TMC                            | 1133 = Lost Keypad Trouble          | N                             | 1196 = Area 6 is Armed Stay          | N                           |       |       |             |       |
| 1006 = Aux1 24 hr, Any Area    | TMC         | 1069 = Emergency Alm in Area 7 | TMC                            | 1134 = Lost Input Expander Tbl      | N                             | 1197 = Area 7 is Armed Stay          | N                           |       |       |             |       |
| 1007 = Aux2 24 hr, Any Area    | TMC         | 1070 = Emergency Alm in Area 8 | TMC                            | 1135 = Lost Output Expander Tbl     | N                             | 1198 = Area 8 is Armed Stay          | N                           |       |       |             |       |
| 1008 = CO Alarm, Any Area      | TMC         |                                |                                | 1136 = EEPROM Memory Error Tbl      | C                             |                                      |                             |       |       |             |       |
| 1009 = Emergency Alm, Any Area | TMC         | 1071 = Freeze Alarm in Area 1  | TMC                            | 1137 = Flash Memory Error Trouble   | C                             | 1199 = Area 1 is Armed Stay Instant  | N                           |       |       |             |       |
| 1010 = Freeze Alarm, Any Area  | TMC         | 1072 = Freeze Alarm in Area 2  | TMC                            | 1138 = AC Failure Trouble           | N                             | 1200 = Area 2 is Armed Stay Instant  | N                           |       |       |             |       |
| 1011 = Gas Alarm, Any Area     | TMC         | 1073 = Freeze Alarm in Area 3  | TMC                            | 1139 = Control Low Battery Trouble  | N                             | 1201 = Area 3 is Armed Stay Instant  | N                           |       |       |             |       |
| 1012 = Heat Alarm, Any Area    | TMC         | 1074 = Freeze Alarm in Area 4  | TMC                            | 1140 = Control Over Current Trouble | N                             | 1202 = Area 4 is Armed Stay Instant  | N                           |       |       |             |       |
| 1013 = Water Alarm, Any Area   | TMC         | 1075 = Freeze Alarm in Area 5  | TMC                            | 1141 = Expansion Module Trouble     | N                             | 1203 = Area 5 is Armed Stay Instant  | N                           |       |       |             |       |
| 1014 = Alarm, Any Area         | TMC         | 1076 = Freeze Alarm in Area 6  | TMC                            | 1142 = Output 2 Supervisory Tbl     | N                             | 1204 = Area 6 is Armed Stay Instant  | N                           |       |       |             |       |
|                                |             | 1077 = Freeze Alarm in Area 7  | TMC                            | 1143 = Telephone Line Fault Tbl     | N                             | 1205 = Area 7 is Armed Stay Instant  | N                           |       |       |             |       |
|                                |             | 1078 = Freeze Alarm in Area 8  | TMC                            |                                     |                               | 1206 = Area 8 is Armed Stay Instant  | N                           |       |       |             |       |
| 1015 = Burglar Alarm in Area 1 | TMC         |                                |                                | 1144 = Restore Fire Zone            | B                             |                                      |                             |       |       |             |       |
| 1016 = Burglar Alarm in Area 2 | TMC         |                                |                                | 1145 = Restore Fire Supv Zone       | B                             | 1207 = Area 1 is Armed Night         | N                           |       |       |             |       |
| 1017 = Burglar Alarm in Area 3 | TMC         | 1079 = Gas Alarm in Area 1     | TMC                            | 1146 = Restore Burglar Zone         | B                             | 1208 = Area 2 is Armed Night         | N                           |       |       |             |       |
| 1018 = Burglar Alarm in Area 4 | TMC         | 1080 = Gas Alarm in Area 2     | TMC                            | 1147 = Restore Medical Zone         | B                             | 1209 = Area 3 is Armed Night         | N                           |       |       |             |       |
| 1019 = Burglar Alarm in Area 5 | TMC         | 1081 = Gas Alarm in Area 3     | TMC                            | 1148 = Restore Police Zone          | B                             | 1210 = Area 4 is Armed Night         | N                           |       |       |             |       |
| 1020 = Burglar Alarm in Area 6 | TMC         | 1082 = Gas Alarm in Area 4     | TMC                            | 1149 = Restore Aux1 24 hr Zone      | B                             | 1211 = Area 5 is Armed Night         | N                           |       |       |             |       |
| 1021 = Burglar Alarm in Area 7 | TMC         | 1083 = Gas Alarm in Area 5     | TMC                            | 1150 = Restore Aux2 24 hr Zone      | B                             | 1212 = Area 6 is Armed Night         | N                           |       |       |             |       |
| 1022 = Burglar Alarm in Area 8 | TMC         | 1084 = Gas Alarm in Area 6     | TMC                            | 1151 = Restore CO Zone              | B                             | 1213 = Area 7 is Armed Night         | N                           |       |       |             |       |
|                                |             | 1085 = Gas Alarm in Area 7     | TMC                            | 1152 = Restore Emergency Zone       | B                             | 1214 = Area 8 is Armed Night         | N                           |       |       |             |       |
|                                |             | 1086 = Gas Alarm in Area 8     | TMC                            | 1153 = Restore Freezer Zone         | B                             |                                      |                             |       |       |             |       |
| 1023 = Medical Alarm in Area 1 | TMC         |                                |                                | 1154 = Restore Gas Zone             | B                             | 1215 = Area 1 is Armed Night Instant | N                           |       |       |             |       |
| 1024 = Medical Alarm in Area 2 | TMC         |                                |                                | 1155 = Restore Heat Zone            | B                             | 1216 = Area 2 is Armed Night Instant | N                           |       |       |             |       |
| 1025 = Medical Alarm in Area 3 | TMC         | 1087 = Heat Alarm in Area 1    | TMC                            | 1156 = Restore Water Zone           | B                             | 1217 = Area 3 is Armed Night Instant | N                           |       |       |             |       |
| 1026 = Medical Alarm in Area 4 | TMC         | 1088 = Heat Alarm in Area 2    | TMC                            | 1157 = Communication Fail Restore   | B                             | 1218 = Area 4 is Armed Night Instant | N                           |       |       |             |       |
| 1027 = Medical Alarm in Area 5 | TMC         | 1089 = Heat Alarm in Area 3    | TMC                            | 1158 = AC Fail Restore              | B                             | 1219 = Area 5 is Armed Night Instant | N                           |       |       |             |       |
| 1028 = Medical Alarm in Area 6 | TMC         | 1090 = Heat Alarm in Area 4    | TMC                            | 1159 = Low Battery Restore          | B                             | 1220 = Area 6 is Armed Night Instant | N                           |       |       |             |       |
| 1029 = Medical Alarm in Area 7 | TMC         | 1091 = Heat Alarm in Area 5    | TMC                            | 1160 = Control Over Current Restore | B                             | 1221 = Area 7 is Armed Night Instant | N                           |       |       |             |       |
| 1030 = Medical Alarm in Area 8 | TMC         | 1092 = Heat Alarm in Area 6    | TMC                            | 1161 = Expansion Module Restore     | B                             | 1222 = Area 8 is Armed Night Instant | N                           |       |       |             |       |
|                                |             | 1093 = Heat Alarm in Area 7    | TMC                            | 1162 = Output 2 Restore             | B                             |                                      |                             |       |       |             |       |
|                                |             | 1094 = Heat Alarm in Area 8    | TMC                            | 1163 = Telephone Line Restore       | B                             | 1223 = Area 1 is Armed Vacation      | N                           |       |       |             |       |
| 1031 = Police Alarm in Area 1  | TMC         | 1095 = Water Alarm in Area 1   | TMC                            |                                     |                               | 1224 = Area 2 is Armed Vacation      | N                           |       |       |             |       |
| 1032 = Police Alarm in Area 2  | TMC         | 1096 = Water Alarm in Area 2   | TMC                            | 1164 = Alarm Memory                 | A                             | 1225 = Area 4 is Armed Vacation      | N                           |       |       |             |       |
| 1033 = Police Alarm in Area 3  | TMC         | 1097 = Water Alarm in Area 3   | TMC                            | 1165 = Alarm Memory in Area 1       | TMC                           | 1226 = Area 4 is Armed Vacation      | N                           |       |       |             |       |
| 1034 = Police Alarm in Area 4  | TMC         | 1098 = Water Alarm in Area 4   | TMC                            | 1166 = Alarm Memory in Area 2       | TMC                           | 1227 = Area 5 is Armed Vacation      | N                           |       |       |             |       |
| 1035 = Police Alarm in Area 5  | TMC         | 1099 = Water Alarm in Area 5   | TMC                            | 1167 = Alarm Memory in Area 3       | TMC                           | 1228 = Area 6 is Armed Vacation      | N                           |       |       |             |       |
| 1036 = Police Alarm in Area 6  | TMC         | 1100 = Water Alarm in Area 6   | TMC                            | 1168 = Alarm Memory in Area 4       | TMC                           | 1229 = Area 7 is Armed Vacation      | N                           |       |       |             |       |
| 1037 = Police Alarm in Area 7  | TMC         | 1101 = Water Alarm in Area 7   | TMC                            | 1169 = Alarm Memory in Area 5       | TMC                           | 1230 = Area 8 is Armed Vacation      | N                           |       |       |             |       |
| 1038 = Police Alarm in Area 8  | TMC         | 1102 = Water Alarm in Area 8   | TMC                            | 1170 = Alarm Memory in Area 6       | TMC                           |                                      |                             |       |       |             |       |
|                                |             |                                |                                | 1171 = Alarm Memory in Area 7       | TMC                           | 1231 = Area 1 is Force Armed         | N                           |       |       |             |       |
| 1039 = Aux1 24 hr in Area 1    | TMC         | 1103 = Any Alarm in Area 1     | TMC                            | 1172 = Alarm Memory in Area 8       | TMC                           | 1232 = Area 2 is Force Armed         | N                           |       |       |             |       |
| 1040 = Aux1 24 hr in Area 2    | TMC         | 1104 = Any Alarm in Area 2     | TMC                            |                                     |                               | 1233 = Area 3 is Force Armed         | N                           |       |       |             |       |
| 1041 = Aux1 24 hr in Area 3    | TMC         | 1105 = Any Alarm in Area 3     | TMC                            | 1173 = Area Armed                   | N                             | 1234 = Area 4 is Force Armed         | N                           |       |       |             |       |
| 1042 = Aux1 24 hr in Area 4    | TMC         | 1106 = Any Alarm in Area 4     | TMC                            | 1174 = Area Disarmed                | N                             | 1235 = Area 5 is Force Armed         | N                           |       |       |             |       |
| 1043 = Aux1 24 hr in Area 5    | TMC         | 1107 = Any Alarm in Area 5     | TMC                            | 1175 = Area 1 Arm State             | N                             | 1236 = Area 6 is Force Armed         | N                           |       |       |             |       |
| 1044 = Aux1 24 hr in Area 6    | TMC         | 1108 = Any Alarm in Area 6     | TMC                            | 1176 = Area 2 Arm State             | N                             | 1237 = Area 7 is Force Armed         | N                           |       |       |             |       |
| 1045 = Aux1 24 hr in Area 7    | TMC         | 1109 = Any Alarm in Area 7     | TMC                            | 1177 = Area 3 Arm State             | N                             | 1238 = Area 8 is Force Armed         | N                           |       |       |             |       |
| 1046 = Aux1 24 hr in Area 8    | TMC         | 1110 = Any Alarm in Area 8     | TMC                            | 1178 = Area 4 Arm State             | N                             |                                      |                             |       |       |             |       |
|                                |             |                                |                                | 1179 = Area 5 Arm State             | N                             | 1239 = Zone Bypassed                 | N                           |       |       |             |       |
| 1047 = Aux2 24 hr in Area 1    | TMC         | 1111 = Any Keypad Code-Lockout | N                              | 1180 = Area 6 Arm State             | N                             | 1240 = All Zones Unbypassed          | B                           |       |       |             |       |
| 1048 = Aux2 24 hr in Area 2    | TMC         | 1112 = Keypad 01 Code-Lockout  | N                              | 1181 = Area 7 Arm State             | N                             | 1241 = Burglar Zone Fault            | N                           |       |       |             |       |
| 1049 = Aux2 24 hr in Area 3    | TMC         | 1113 = Keypad 02 Code-Lockout  | N                              | 1182 = Area 8 Arm State             | N                             |                                      |                             |       |       |             |       |
| 1050 = Aux2 24 hr in Area 4    | TMC         | 1114 = Keypad 03 Code-Lockout  | N                              |                                     |                               | 1242 = Burglar Status                | N                           |       |       |             |       |
| 1051 = Aux2 24 hr in Area 5    | TMC         | 1115 = Keypad 04 Code-Lockout  | N                              | 1183 = Area 1 is Armed Away         | N                             | 1243 = Area 1 Burglar Status         | N                           |       |       |             |       |
| 1052 = Aux2 24 hr in Area 6    | TMC         | 1116 = Keypad 05 Code-Lockout  | N                              | 1184 = Area 2 is Armed Away         | N                             | 1244 = Area 2 Burglar Status         | N                           |       |       |             |       |
| 1053 = Aux2 24 hr in Area 7    | TMC         | 1117 = Keypad 06 Code-Lockout  | N                              | 1185 = Area 3 is Armed Away         | N                             | 1245 = Area 3 Burglar Status         | N                           |       |       |             |       |
| 1054 = Aux2 24 hr in Area 8    | TMC         | 1118 = Keypad 07 Code-Lockout  | N                              | 1186 = Area 4 is Armed Away         | N                             | 1246 = Area 4 Burglar Status         | N                           |       |       |             |       |
|                                |             | 1119 = Keypad 08 Code-Lockout  | N                              | 1187 = Area 5 is Armed Away         | N                             | 1247 = Area 5 Burglar Status         | N                           |       |       |             |       |
| 1055 = CO Alarm in Area 1      | TMC         | 1120 = Keypad 09 Code-Lockout  | N                              | 1188 = Area 6 is Armed Away         | N                             | 1248 = Area 6 Burglar Status         | N                           |       |       |             |       |
| 1056 = CO Alarm in Area 2      | TMC         | 1121 = Keypad 10 Code-Lockout  | N                              | 1189 = Area 7 is Armed Away         | N                             | 1249 = Area 7 Burglar Status         | N                           |       |       |             |       |
| 1057 = CO Alarm in Area 3      | TMC         | 1122 = Keypad 11 Code-Lockout  | N                              | 1190 = Area 8 is Armed Away         | N                             | 1250 = Area 8 Burglar Status         | N                           |       |       |             |       |
| 1058 = CO Alarm in Area 4      | TMC         | 1123 = Keypad 12 Code-Lockout  | N                              |                                     |                               |                                      |                             |       |       |             |       |
| 1059 = CO Alarm in Area 5      | TMC         | 1124 = Keypad 13 Code-Lockout  | N                              |                                     |                               |                                      |                             |       |       |             |       |
| 1060 = CO Alarm in Area 6      | TMC         | 1125 = Keypad 14 Code-Lockout  | N                              |                                     |                               |                                      |                             |       |       |             |       |
| 1061 = CO Alarm in Area 7      | TMC         | 1126 = Keypad 15 Code-Lockout  | N                              |                                     |                               |                                      |                             |       |       |             |       |
| 1062 = CO Alarm in Area 8      | TMC         | 1127 = Keypad 16 Code-Lockout  | N                              |                                     |                               |                                      |                             |       |       |             |       |

# Appendix A - Event Codes (cont.)

| Event | Description                 | Reset | Event        | Description                    | Reset | Event          | Description                 | Reset |
|-------|-----------------------------|-------|--------------|--------------------------------|-------|----------------|-----------------------------|-------|
| 1251  | = Area 1 Chime Mode         | N     | 1313         | = Access Keypad 1              | TM    | 2001           | = Automation Control 1      | TF    |
| 1252  | = Area 2 Chime Mode         | N     | 1314         | = Access Keypad 2              | TM    | -              |                             |       |
| 1253  | = Area 3 Chime Mode         | N     | 1315         | = Access Keypad 3              | TM    | 2032           | = Automation Control 32     | TF    |
| 1254  | = Area 4 Chime Mode         | N     | 1316         | = Access Keypad 4              | TM    |                |                             |       |
| 1255  | = Area 5 Chime Mode         | N     | 1317         | = Access Keypad 5              | TM    | 2033 to 3000   | = No Event/Not Used         | N     |
| 1256  | = Area 6 Chime Mode         | N     | 1318         | = Access Keypad 6              | TM    |                |                             |       |
| 1257  | = Area 7 Chime Mode         | N     | 1319         | = Access Keypad 7              | TM    | 3001           | = F1 Key on Keypad 1        | F     |
| 1258  | = Area 8 Chime Mode         | N     | 1320         | = Access Keypad 8              | TM    | 3002           | = F2 Key on Keypad 1        | F     |
|       |                             |       | 1321         | = Access Keypad 9              | TM    | 3003           | = F3 Key on Keypad 1        | F     |
| 1259  | = Area 1 Chime Alert        | B     | 1322         | = Access Keypad 10             | TM    | 3004           | = F4 Key on Keypad 1        | F     |
| 1260  | = Area 2 Chime Alert        | B     | 1323         | = Access Keypad 11             | TM    | 3005           | = F5 Key on Keypad 1        | F     |
| 1261  | = Area 3 Chime Alert        | B     | 1324         | = Access Keypad 12             | TM    | 3006           | = F6 Key on Keypad 1        | F     |
| 1262  | = Area 4 Chime Alert        | B     | 1325         | = Access Keypad 13             | TM    | 3007 to 3012   | = F1 to F6 on KP 2          | F     |
| 1263  | = Area 5 Chime Alert        | B     | 1326         | = Access Keypad 14             | TM    | 3013 to 3018   | = F1 to F6 on KP 3          | F     |
| 1264  | = Area 6 Chime Alert        | B     | 1327         | = Access Keypad 15             | TM    | 3019 to 3024   | = F1 to F6 on KP 4          | F     |
| 1265  | = Area 7 Chime Alert        | B     | 1328         | = Access Keypad 16             | TM    | 3025 to 3030   | = F1 to F6 on KP 5          | F     |
| 1266  | = Area 8 Chime Alert        | B     | 1329         | = Access, Any Keypad           | TM    | 3031 to 3036   | = F1 to F6 on KP 6          | F     |
|       |                             |       |              |                                |       | 3037 to 3042   | = F1 to F6 on KP 7          | F     |
| 1267  | = Entry Delay Active        | N     | 1330         | = Keypad Beep Area 1           | N     | 3043 to 3048   | = F1 to F6 on KP 8          | F     |
| 1268  | = Area 1 Entry Delay        | N     | 1331         | = Keypad Beep Area 2           | N     | 3049 to 3054   | = F1 to F6 on KP 9          | F     |
| 1269  | = Area 2 Entry Delay        | N     | 1332         | = Keypad Beep Area 3           | N     | 3055 to 3060   | = F1 to F6 on KP 10         | F     |
| 1270  | = Area 3 Entry Delay        | N     | 1333         | = Keypad Beep Area 4           | N     | 3061 to 3066   | = F1 to F6 on KP 11         | F     |
| 1271  | = Area 4 Entry Delay        | N     | 1334         | = Keypad Beep Area 5           | N     | 3067 to 3072   | = F1 to F6 on KP 12         | F     |
| 1272  | = Area 5 Entry Delay        | N     | 1335         | = Keypad Beep Area 6           | N     | 3073 to 3078   | = F1 to F6 on KP 13         | F     |
| 1273  | = Area 6 Entry Delay        | N     | 1336         | = Keypad Beep Area 7           | N     | 3079 to 3084   | = F1 to F6 on KP 14         | F     |
| 1274  | = Area 7 Entry Delay        | N     | 1337         | = Keypad Beep Area 8           | N     | 3085 to 3090   | = F1 to F6 on KP 15         | F     |
| 1275  | = Area 8 Entry Delay        | N     |              |                                |       | 3091 to 3096   | = F1 to F6 on KP 16         | F     |
|       |                             |       | 1338         | = Area 1 Exit Error            | N     |                |                             |       |
| 1276  | = Exit Delay Active         | N     | 1339         | = Area 2 Exit Error            | N     | 3097           | = F1 Key, Any KP Is Pressed | B     |
| 1277  | = Area 1 Exit Delay         | N     | 1340         | = Area 3 Exit Error            | N     | 3098           | = F2 Key, Any KP Is Pressed | B     |
| 1278  | = Area 2 Exit Delay         | N     | 1341         | = Area 4 Exit Error            | N     | 3099           | = F3 Key, Any KP Is Pressed | B     |
| 1279  | = Area 3 Exit Delay         | N     | 1342         | = Area 5 Exit Error            | N     | 3100           | = F4 Key, Any KP Is Pressed | B     |
| 1280  | = Area 4 Exit Delay         | N     | 1343         | = Area 6 Exit Error            | N     | 3101           | = F5 Key, Any KP Is Pressed | B     |
| 1281  | = Area 5 Exit Delay         | N     | 1344         | = Area 7 Exit Error            | N     | 3102           | = F6 Key, Any KP Is Pressed | B     |
| 1282  | = Area 6 Exit Delay         | N     | 1345         | = Area 8 Exit Error            | N     | 3103           | = Any KP Key Is Pressed     | F     |
| 1283  | = Area 7 Exit Delay         | N     |              |                                |       | 3104 to 4000   | = No Event                  |       |
| 1284  | = Area 8 Exit Delay         | N     | 1346         | = Audio Amplifier Status       | TMC   |                |                             |       |
|       |                             |       | 1347         | = Control Power Status         | N     | 4001 to 4208   | = Zone State 1 to 208       | T     |
| 1285  | = Area 1 Exit Delay Expires | N     | 1348         | = Light                        | N     | 4209 to 5000   | = No Event                  |       |
| 1286  | = Area 2 Exit Delay Expires | N     | 1349         | = Dark                         | N     |                |                             |       |
| 1287  | = Area 3 Exit Delay Expires | N     | 1350         | = Security (Day) Alert         | TMC   | 5001 to 5208   | = Bypass State 1 to 208T    |       |
| 1288  | = Area 4 Exit Delay Expires | N     | 1351         | = Dialer Abort                 | B     | 5209 to 6000   | = No Event                  |       |
| 1289  | = Area 5 Exit Delay Expires | N     | 1352         | = Dialer Cancel                | B     |                |                             |       |
| 1290  | = Area 6 Exit Delay Expires | N     | 1353         | = Dialer Auto Test             | B     | 6001 to 6208   | = Alm Memory 1 to 208       | T     |
| 1291  | = Area 7 Exit Delay Expires | N     | 1354         | = Local Programming Begin      | N     | 6209 to 7000   | = No Event                  |       |
| 1292  | = Area 8 Exit Delay Expires | N     | 1355         | = Local Programming End        | B     |                |                             |       |
|       |                             |       | 1356         | = Keyswitch Security Alert     | TMC   | 7001 to 7208   | = Output State 1 to 208     | N     |
| 1293  | = Automatic Closing         | B     | 1357         | = Event Log is 80% Full        | N     | 7209 to 8000   | = No Event                  |       |
| 1294  | = Early Closing             | B     | 1358         | = Telephone Line Is Ringing    | B     |                |                             |       |
| 1295  | = Closing Time Extended     | B     | 1359         | = Telephone Line Seized Status | T     | 8001 thru 9999 | = No Event                  |       |
| 1296  | = Fail to Close             | B     | 1360         | = Telephone Line Hook Status   | T     |                |                             |       |
| 1297  | = Late to Close             | B     | 1361         | = Telephone Local Access       | T     |                |                             |       |
| 1298  | = Keyswitch Closing         | B     | 1362         | = Telephone Remote Access      | T     |                |                             |       |
| 1299  | = Duress                    | B     | 1363         | = Remote Programming Start     | N     |                |                             |       |
| 1300  | = Exception Opening         | B     | 1364         | = Remote Programming Stop      | B     |                |                             |       |
| 1301  | = Early Opening             | B     | 1365         | = AC Fail Tbl - Power Supv Zn  | N     |                |                             |       |
| 1302  | = Fail to Open              | B     | 1366         | = Low Batt Tbl - Pwr Supv Zn   | N     |                |                             |       |
| 1303  | = Late to Open              | B     | 1367         | = System Start Up              | B     |                |                             |       |
| 1304  | = Keyswitch Opening         | B     | 1368         | = Control Low Volt Shutdown    | N     |                |                             |       |
|       |                             |       | 1369         | = RF Keyfob Button 1           | B     |                |                             |       |
| 1305  | = Area 1 Closing Ring Back  | B     | 1370         | = RF Keyfob Button 2           | B     |                |                             |       |
| 1306  | = Area 2 Closing Ring Back  | B     | 1371         | = RF Keyfob Button 3           | B     |                |                             |       |
| 1307  | = Area 3 Closing Ring Back  | B     | 1372         | = RF Keyfob Button 4           | B     |                |                             |       |
| 1308  | = Area 4 Closing Ring Back  | B     | 1373         | = RF Keyfob Button 5           | B     |                |                             |       |
| 1309  | = Area 5 Closing Ring Back  | B     | 1374         | = RF Keyfob Button 6           | B     |                |                             |       |
| 1310  | = Area 6 Closing Ring Back  | B     | 1375         | = RF Keyfob Button 7           | B     |                |                             |       |
| 1311  | = Area 7 Closing Ring Back  | B     | 1376         | = RF Keyfob Button 8           | B     |                |                             |       |
| 1312  | = Area 8 Closing Ring Back  | B     | 1377         | = Lost Serial Port Exp Tbl     | N     |                |                             |       |
|       |                             |       | 1378         | = Rule Triggered Voice Dial    | B     |                |                             |       |
|       |                             |       | 1379         | = Dialer Report Cleared        | B     |                |                             |       |
|       |                             |       | 1380         | = Central Station Kissoff      | B     |                |                             |       |
|       |                             |       | 1381         | = Transmitter Supervision Loss | N     |                |                             |       |
|       |                             |       | 1382 to 2000 | = No Event/Not Used            |       |                |                             |       |

### "Reset" Attribute

The letter(s) displayed in Reset column indicate what condition(s) it takes to clear an event once it has been activated.

For example, the letters TMC indicate the event will reset when the output timer ends, or when manually turned off, or when a valid user code is entered, whichever comes first.

### NOTE:

The reset attributes are shown only for informational purposes. They are set by the factory and cannot be altered.

- N (0) Event follows the activation
- T (1) Event clears when output timer ends
- M (2) Event clears when manually turned off
- C (4) Event clears upon User Code entry
- A (16) Event clears upon Arming
- D (32) Event clears upon Disarming
- B (64) Event clears almost immediately "Blip"
- F (128) Event toggles with each activation

# Appendix B - Telephone Remote Control

## There are two methods of entry:

1. Local – Lift house phone off-hook. Enter \* \* \*. (To hear over the inside speakers press \* 0 \* instead.)

Once the control hears the pickup sequence it will go offhook and announce a welcome message. It will then prompt the user to enter a valid user passcode.

If the User Code is validated the control will announce the main menu selections. These selections are shown below along with the sub menu items for each level.

Main Menu Example: FOR ARM STATUS PRESS 1, FOR AUTOMATION CONTROL PRESS 2, FOR TROUBLE STATUS PRESS 3, FOR ZONE STATUS PRESS 4, FOR AUDIO MONITOR PRESS 7, TO EXIT AND HANG-UP PRESS 9.

2. Off site – Dial phone number of control (the control must have a programmed number of rings till answer). Wait for control or answering machine to pick up. If an answering machine picks up enter \*\*\*, then enter 1. A voice message will ask for security code. If the control answers then wait for three short beep tones and then enter your code.

## Menu listing: Main menu options are underlined.

**For Help - press 0.** A voice message will explain the function of each key.

**For Arm Status - press 1.** A voice message will identify whether the system is currently armed or disarmed and will allow the state to be changed. There are two options:

If Disarmed - Press 1 for list of Arming options. There are 6 options:

- Press 1 for Away mode.
- Press 2 for Stay mode.
- Press 3 for Stay Instant mode.
- Press 4 for Armed Night mode.
- Press 5 for Armed Night Instant mode.
- Press 6 for Vacation mode.

If Armed – Press 2 to disarm.

**For Automation - press 2.** A voice message will prompting you to select one of the following automation options:

**For Automation Task - press 1.** Tasks are like computer macros. They can be programmed and named using the RP software and are used to perform a chain or series of events upon activation. Upon entry into this menu, any task which was designated to "Show" will be announced by name and by number. To choose a task, enter its number. For fastest operation, add a 0 in front of single digit numbers. I.E. for a 3 enter 03. NOTE: Any valid task can be selected by entering it's two digit number, even if it was not announced. The task name will then be repeated along with the prompt: **To Activate - press #.** This should cause the events to activate.

**For Light Control - press 2.** This menu allows direct control any light device and can even be used for PLC appliance modules. Lights are programmed and named using RP software. Upon entry into this menu, any light which was designated to "Show" will be announced by name and number. To choose a light, enter it's three digit number. For fastest operation, add 0's in front of numbers less than three digits. NOTE: Any valid light can be selected by entering it's three digit number, even if it was not announced. The light name will then be repeated along with it's current status (On/Off) and the prompt: **To Change - press #.** The light should change state.

**For Output Control - press 3.** This menu allows direct control any valid output on the control. Outputs are programmed and named using RP software. Upon entry into this menu, any output which was designated to "Show" will be announced by name and number. To choose an output, enter it's three digit number. For fastest operation, add 0's in front of numbers less than three digits. NOTE: Any valid output can be selected by entering it's three digit number, even if it was not announced. The output name will then be repeated along with it's current status (On/Off) and the prompt: **To Change - press #.** The output should change state.

**For Sensor Temperature - press 4.** Temperature sensors can be connected to the first 16 zones on the control. This menu allows you to hear the current temperature of any valid sensor. Upon entry into this menu, any sensor programmed with a name and designated to "Show" by the RP software will be announced by name and number. To choose a sensor, enter it's two digit number. Add 0's in front of numbers single digits. NOTE: Any valid sensor can be selected by entering it's two digit number, even if it was not announced. The sensor name will then be repeated along with it's current reading.

# Appendix B - Telephone Remote Control (cont.)

## Automation Menu continued

**For Keypad Temperature - press 5.** Certain models of keypads have a built-in temperature sensor. This menu allows you to hear the current temperature of any valid keypad sensor. Upon entry into this menu, any keypad sensor programmed with a name and designated to "Show" by the RP software will be announced by name and number. To choose a keypad sensor, enter its two digit number. Add 0's in front of numbers single digits. NOTE: Any valid keypad sensor can be selected by entering its two digit number, even if it was not announced. The keypad sensor name will then be repeated along with its current reading.

**For Thermostat Temperature - press 6.** Specific brands of HVAC thermostats can be connected to the control. This menu allows you to hear the current temperature of any valid thermostat. Upon entry into this menu, any thermostat programmed with a name and designated to "Show" by the RP software will be announced by name and number. To choose a thermostat, enter its two digit number. Add 0's in front of numbers single digits. NOTE: Any valid thermostat can be selected by entering its two digit number, even if it was not announced. The thermostat name will then be repeated along with its current reading.

**For System Trouble Status press 3.** Upon entry into this menu, any current system troubles will be announced by name. This will deliver a voice message stating that system is normal or the first system trouble that is present. Options: Each time 3 is pressed the next system trouble is identified.

**For Zone Status press 4.** Upon entry into this menu, any current zone troubles will be announced by name. This will deliver a voice message stating either that "no zones violated" or "zone xx violated". Additional presses of the 4 key will announce additional troubled zones, if any exist.

**For Audio Alert press 7.** This only works if a 2 way listen-in interface is installed. (Ness-M1TWI part # 101-217) It will open an audio path from the phone to the listen-in board and the output 1 speakers. For full operating instructions see Appendix D.

**To hang-up press 9.** This will deliver the good-bye voice message. The telephone remote control operation has ending.

**To hear menu options press 0.** This will deliver a voice message explaining the function of each key.

\* NOTE: If no response or key presses are heard by the control, the item or menu will be repeated once again. If no key presses are received within a 30 second time frame the message "Hanging Up, Good-bye" will be heard and the control will then disconnect.

### WHAT HAPPENS IF THE PHONE LINE IS BUSY?

If the dialer is in use (such as during an alarm message report) then no dial tone will be heard and the offhook sequence will be ignored. The best thing to do at that point is to try again later (when the dialer is free) or hold onto the phone and wait till dialer hangs up. When the phone line is released (idle) dial tone will again be heard and you can then enter the offhook sequence.

### WHAT HAPPENS IF AN ALARM OCCURS?

If the control is programmed to communicate alarms to a central monitoring station, it will automatically pick up the phone line and disconnect all calls when an alarm occurs. During this time period the telephone remote control will be inoperable. However, the installer may elect to program a communicator delay before dial time which would permit the telephone remote to function for a short time period immediately after an alarm. During this time it would be possible to enter the offhook sequence of \* \* \* and enter all the proper codes to disarm and/silence the alarm.

# Appendix C - Voice Message Vocabulary \*RP only \*

## Word or Phrase

(Blank) = 0  
Zero = 21  
One = 22  
Two = 23  
Three = 24  
Four = 25  
Five = 26  
Six = 27  
Seven = 28  
Eight = 29  
Nine = 30  
Ten = 31  
Eleven = 32  
Twelve = 33  
Thirteen = 34  
Fourteen = 35  
Fifteen = 36  
Sixteen = 37  
Seventeen = 38  
Eighteen = 39  
Nineteen = 40  
Twenty = 41  
Thirty = 42  
Forty = 43  
Fifty = 44  
Sixty = 45  
Seventy = 46  
Eighty = 47  
Ninety = 48  
Hundred = 49  
Thousand = 50  
[200ms Silence] = 51  
[500ms Silence] = 52  
[800hz Tone] = 53

## A

A = 54  
Access = 55  
Acknowledged = 56  
AC power = 57  
Activate = 58  
Activated = 59  
Active = 60  
Adjust = 61  
Air = 62  
Alarm = 63  
Alert = 64  
All = 65  
AM = 66  
An = 67  
And = 68  
Answer = 69  
Any = 70  
Are = 71  
Area = 72  
Arm = 73  
Armed = 74  
At = 75  
Attic = 76  
Audio = 77  
Auto = 78  
Authorized = 79  
Automatic = 80  
Automation = 81  
Auxiliary = 82  
Away = 83

## Word or Phrase

**B**  
B = 84  
Back = 85  
Barn = 86  
Basement = 87  
Bathroom = 88  
Battery = 89  
Bedroom = 90  
Been = 91  
Bell = 92  
Bottom = 93  
Break = 94  
Breakfast = 95  
Bright = 96  
Building = 97  
Burglar = 98  
Button = 99  
By = 100  
Bypassed = 101

## C

Cabinet = 102  
Call = 103  
Camera = 104  
Cancel = 105  
Carbon monoxide = 106  
Card = 107  
Center = 108  
Central = 109  
Change = 110  
Check = 111  
Chime = 112  
Circuit = 113  
Clear = 114  
Closed = 115  
Closet = 116  
Code = 117  
Cold = 118  
Condition = 119  
Connect = 120  
Control = 121  
Cool = 122  
Cooling = 123  
Corner = 124  
Crawlspace = 125

## D

Danger = 126  
Day = 127  
Deck = 128  
Decrease = 129  
Defective = 130  
Degrees = 131  
Delay = 132  
Den = 133  
Denied = 134  
Detected = 135  
Detector = 136  
Device = 137  
Dial = 138  
Dialing = 139  
Dim = 140  
Dining room = 141  
Disable = 142  
Disarm = 143  
Disarmed = 144  
Dock = 145  
Door = 146

## Word or Phrase

Doors = 147  
Down = 148  
Driveway = 149  
**E**  
East = 150  
Emergency = 151  
Enable = 152  
End = 153  
Energy = 154  
Enrollment = 155  
Enter = 156  
Entering = 157  
Entertainment = 158  
Enter the = 159  
Entry = 160  
Environment = 161  
Equipment = 162  
Error = 163  
Evacuate = 164  
Event = 165  
Exercise = 166  
Expander = 167  
Exit = 168  
Exterior = 169

## F

F = 170  
Fail = 171  
Failure = 172  
Family room = 173  
Fan = 174  
Feed = 175  
Fence = 176  
Fire = 177  
First = 178  
Flood = 179  
Floor = 180  
Followed = 181  
Force = 182  
Fountain = 183  
Foyer = 184  
Freeze = 185  
Front = 186  
Full = 187  
Furnace = 188  
Fuse = 189

## G

Game = 190  
Garage = 191  
Gas = 192  
Gate = 193  
Glass = 194  
Go = 195  
Good = 196  
Good-bye = 197  
Great = 198  
Group = 199  
Guest = 200  
Gun = 201

## H

Hall = 202  
Hallway = 203  
Hanging up = 204  
Hang up = 205  
Has = 206

## Word or Phrase

Has Expired = 207  
Have = 208  
Hear menu options = 209  
Heat = 210  
Help = 211  
High = 212  
Hold = 213  
Home = 214  
Hot = 215  
Hot tub = 216  
House = 217  
Humidity = 218  
HVAC = 219

## I

If = 220  
Immediately = 221  
In = 222  
Inches = 223  
Increase = 224  
Inner = 225  
Input = 226  
Inside = 227  
Instant = 228  
Interior = 229  
In The = 230  
Intruder = 231  
Intrusion = 232  
Invalid = 233  
Is = 234  
Is about to expire = 235  
Is active = 236  
Is armed = 237  
Is canceled = 238  
Is closed = 239  
Is disarmed = 240  
Is low = 241  
Is off = 242  
Is OK = 243  
Is on = 244  
Is open = 245

## J

Jacuzzi = 246  
Jewelry = 247

## K

Keep = 248  
Key = 249  
Keypad = 250  
Kitchen = 251

## L

Lamp = 252  
Laundry = 253  
Lawn = 254  
Leak = 255  
Leave = 256  
Left = 257  
Less = 258  
Level = 259  
Library = 260  
Light = 261  
Lights = 262  
Line = 263  
Living room = 264  
Loading = 265  
Lobby = 266

# Appendix C - Voice Message Vocabulary (cont.)

## Word or Phrase

Location = 267  
 Lock = 268  
 Low = 269  
 Lower = 270

### M

M = 271  
 Machine = 272  
 Mail = 273  
 Main = 274  
 Mains = 275  
 Manual = 276  
 Master = 277  
 Max = 278  
 Media = 279  
 Medical = 280  
 Medicine = 281  
 Memory = 282  
 Menu = 283  
 Message = 284  
 Middle = 285  
 Minute = 286  
 Missing = 287  
 Mode = 288  
 Module = 289  
 Monitor = 290  
 More = 291  
 Motion = 292  
 Motor = 293

### N

Next = 294  
 Night = 295  
 No = 296  
 Normal = 297  
 North = 298  
 Not = 299  
 Notified = 300  
 Now = 301  
 Number = 302  
 Nursery = 303

### O

Of = 304  
 Off = 305  
 Office = 306  
 Oh = 307  
 OK = 308  
 On = 309  
 On-line = 310  
 Only = 311  
 Open = 312  
 Operating = 313  
 Option = 314  
 Or = 315  
 Other = 316  
 Out = 317  
 Outlet = 318  
 Output = 319  
 Outside = 320  
 Over = 321  
 Overhead = 322

### P

Panel = 323  
 Panic = 324  
 Parking = 325  
 Partition = 326

## Word or Phrase

Patio = 327  
 Pause = 328  
 Perimeter = 329  
 Personal = 330  
 Phone = 331  
 Place = 332  
 Play = 333  
 Please = 334  
 Plus = 335  
 PM = 336  
 Police = 337  
 Pool = 338  
 Porch = 339  
 Port = 340  
 Pound = 341  
 Pounds = 342  
 Power = 343  
 Press = 344  
 Pressure = 345  
 Problem = 346  
 Program = 347  
 Protected = 348  
 Pump = 349

### R

Radio = 350  
 Raise = 351  
 Ready = 352  
 Rear = 353  
 Receiver = 354  
 Record = 355  
 Recreation = 356  
 Relay = 357  
 Remain calm = 358  
 Remote = 359  
 Repeat = 360  
 Report = 361  
 Reporting = 362  
 Reset = 363  
 Restored = 364  
 Return = 365  
 Right = 366  
 Roof = 367  
 Room = 368  
 Running = 369

### S

Safe = 370  
 Save = 371  
 Screen = 372  
 Second = 373  
 Secure = 374  
 Security = 375  
 Select = 376  
 Sensor = 377  
 Serial = 378  
 Service = 379  
 Set = 380  
 Setback = 381  
 Set point = 382  
 Setting = 383  
 Shed = 384  
 Shipping = 385  
 Shock = 386  
 Shop = 387  
 Shorted = 388  
 Shunted = 389  
 Side = 390

## Word or Phrase

Silence = 391  
 Siren = 392  
 Sliding = 393  
 Smoke = 394  
 Someone = 395  
 South = 396  
 Spare = 397  
 Speaker = 398  
 Sprinkler = 399  
 Stairs = 400  
 Stairway = 401  
 Star = 402  
 Start = 403  
 Status = 404  
 Stay = 405  
 Stock = 406  
 Stop = 407  
 Storage = 408  
 Storm = 409  
 Studio = 410  
 Study = 411  
 Sump = 412  
 Sun = 413  
 Switch = 414  
 System = 415

### T

Tamper = 416  
 Tank = 417  
 Task = 418  
 Telephone = 419  
 Television = 420  
 Temperature = 421  
 Test = 422  
 Thank you = 423  
 That = 424  
 The = 425  
 Theater = 426  
 Thermostat = 427  
 Third = 428  
 Time = 429  
 Toggle = 430  
 Top = 431  
 Transformer = 432  
 Transmitter = 433  
 Trespassing = 434  
 Trouble = 435  
 Turn = 436  
 Twice = 437  
 Type = 438

### U

Under = 439  
 Unit = 440  
 Unlocked = 441  
 Unoccupied = 442  
 Up = 443  
 User = 444  
 Utility = 445

### V

Vacation = 446  
 Valve = 447  
 Video = 448  
 Violated = 449  
 Visitor = 450

## Word or Phrase

**W**  
 Wake up = 451  
 Walk = 452  
 Wall = 453  
 Warehouse = 454  
 Warning = 455  
 Water = 456  
 Way = 457  
 Welcome = 458  
 West = 459  
 What = 460  
 When = 461  
 Where = 462  
 Will = 463  
 Window = 464  
 Windows = 465  
 With = 466  
 Work = 467

### Y

Yard = 468  
 Year = 469  
 You = 470

### Z

Zone = 471  
 Zones = 472

-----  
**Items below are special words and phrases which may be used to resolve unusual situation. For example: Custom 1 thru 10 are 6 second locations that you may custom record. The items shown in [ ] can be used to speak (say) the time, or condition based on the system or zone status.**

'Custom1' = 1  
 'Custom2' = 2  
 'Custom3' = 3  
 'Custom4' = 4  
 'Custom5' = 5  
 'Custom6' = 6  
 'Custom7' = 7  
 'Custom8' = 8  
 'Custom9' = 9  
 'Custom10' = 10

[Insert Condition] = 2  
 [Insert Time] = 3  
 [Intruder Message] = 473  
 [Inverted Condition] = 4  
 [Say Closed/Open] = 509  
 [Say Down/Up] = 507  
 [Say Locked/Unlocked] = 496  
 [Say Not Secure/Secure] = 505  
 [Say Number]  
 [Say Off/On] = 511  
 [Say On/Off] = 512  
 [Say Open/Closed] = 510  
 [Say Secure/Not Secure] = 506  
 [Say Unlocked/Locked] = 495  
 [Say Up/Down] = 508

# Appendix D - Two Way "Listen-in/Talk" Interface (optional)

Using a Two Way Interface board (Ness-M1TWI, part # 101-217), the M1 accommodates up to 3 zones of listen-in. Each zone can have up to 4 microphones for a total of 12 listen-in points. Talk back is delivered through the speakers connected to Output 1. A two way session can be triggered by any number of zones when an alarm occurs. Two way can also be triggered during a Telephone Remote Control session. Instructions for the Ness-M1TWI are included with the interface.

## OPERATION

1. Two way Listen-in must first be enabled from Menu 07-Global System Options. There are two required options. Option 31, "2Way Listen-in Enable" (No or Yes) and Option 32, "2Way Callback Time" (000 to 255 seconds). These options are defaulted to No and 000. In addition, you must also decide which zone(s) need to activate listen-in and set their "Enable Listen-in" programming option. Whenever a Central Station alarm message is transmitted for one of these zones, the dialer provides two methods for initiating a listen-in session.

1a. Hold the Line - After alarm kissoff the dialer will hold the phone line open for the amount of time programmed in Option 32, "2Way Callback Time". This can be from 001 to 255 seconds. During this time the Operator may pick up the line and press \* 55 \* to initiate an immediate two way session. If the control does not receive \* 55 \* during the time period it will hang up and release the phone line.

1b. Callback - Upon hangup the control uses the same time value (Option 32, "2Way Callback Time") to begin a callback time window. During this time window the control will answer any incoming call on the 1st ring, and allow the Operator to press \* 55 \* to initiate a two way session.

2. Two way may also be initiated by calling in using the Telephone Remote Control, and pressing 7 - "Audio Monitor".

3. Once a two way session has begun, it will continue for 3 minutes before automatically disconnecting. To extend the two way session for 3 additional minutes you must press command 7.

## TONE COMMANDS

\* 55 \* BEGIN LISTEN-IN Used by Operator to begin a listen-in session.

- 1 TALK Talk through all speakers connected to Output 1.
- 2 LISTEN All 3 microphone zones are enabled initially. Use key 4 to change mics.
- 3 SENSITIVITY INCREASE Raise the microphone gain.
- 4 MICROPHONE SELECT 4+0 Selects ALL microphones, 4+1 Mic1 zone, 4+2 Mic2 zone, 4+3 Mic3 zone
- 5 [future use]
- 6 SENSITIVITY DECREASE Lowers the microphone gain.
- 7 EXTEND TIME for 3 minutes
- 8 - 8 TERMINATE SESSION and enable 1 ring callback answer for selected time.
- 9 - 9 TERMINATE SESSION without enabling callback answer mode.
- 0 [future use]
- \* CANCEL last key-press (undo)
- # [future use]

Dialer Activated (Alarm)

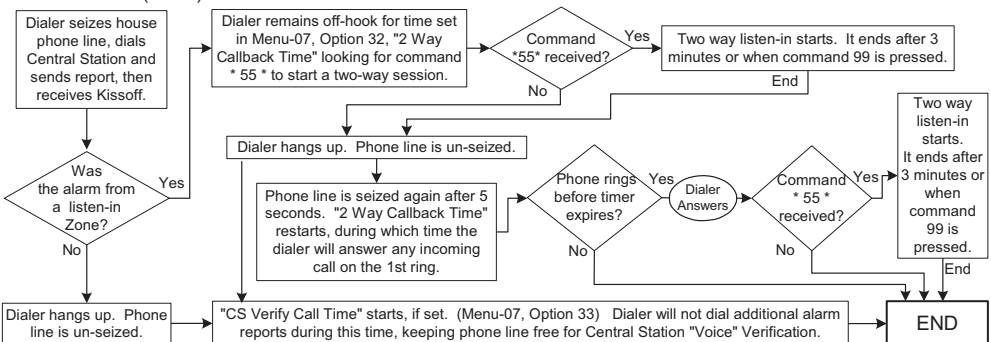



## Appendix E - SIA CP-01 Compliance

| The ELK-M1 complies with the SIA CP-01 Control Panel Standard - Features for False Alarm Reduction<br>PROGRAMMABLE FEATURES, SHIPPING DEFAULTS, AND RECOMMENDED PROGRAMMING |                   |                                         |                                                                                   |                                               |                             |
|-----------------------------------------------------------------------------------------------------------------------------------------------------------------------------|-------------------|-----------------------------------------|-----------------------------------------------------------------------------------|-----------------------------------------------|-----------------------------|
| FEATURE                                                                                                                                                                     | CP-01 Std. Par. # | REQUIREMENT                             | ALLOWABLE RANGE / PURPOSE                                                         | RECOMMENDED PROGRAMMING *                     | SHIPPING DEFAULT            |
| Exit Delay Time 1 & Exit Delay Time 2                                                                                                                                       | 4.2.2.1           | Required (programmable)                 | 45 - 120 sec. (2 minutes) for full or auto arming. Shall not exceed 255 seconds   | 60 Seconds                                    | 60 Seconds                  |
| Silent on Exit (Disable Exit Progress Annunciation - ie: Silent Exit)                                                                                                       | 4.2.2.2           | Allowed                                 | Individual keypads may be disabled                                                | All Audible Annunciators                      | All Audible Annunciators    |
| Exit Time Restart                                                                                                                                                           | 4.2.2.3           | Required Option                         | Only one restart during arming.                                                   | Enabled                                       | Enabled                     |
| Auto Interior Off (Auto "Stay" Arm on Unvacated Premises)                                                                                                                   | 4.2.2.5           | Required Option (except for remote arm) | Away arm changes to Stay Arm if there is no exit detected.                        | Enabled                                       | Enabled                     |
| Entry Delay Time 1 & Entry Delay Time 2                                                                                                                                     | 4.2.3.1           | Required (programmable)                 | 30 sec. to at least 240 sec. (4 minutes) minimum **                               | At least 30 Seconds **                        | 30 Seconds                  |
| Comm Abort Time (Abort Window) for Non-Fire Zones. 000 time = Disabled                                                                                                      | 4.2.5.1           | Required Option                         | May be disabled - by zone or zone type                                            | Enabled (all zones)                           | Enabled                     |
| Comm Abort Window Time - for Non-Fire Zones                                                                                                                                 | 4.2.5.1           | Required (programmable)                 | 15 sec. - 45 sec. **                                                              | At least 15 seconds                           | 30 Seconds                  |
| Abort Annunciation ***                                                                                                                                                      | 4.2.5.1.2         | Required                                | Annunciate that no alarm was transmitted                                          | Enabled                                       | Enabled - No disable option |
| Cancel Annunciation ***                                                                                                                                                     | 4.2.5.4.1         | Required                                | Annunciate that a Cancel was transmitted                                          | Enabled                                       | Enabled - No disable option |
| Duress (Individual User Code Option)                                                                                                                                        | 4.2.6.1 & 4.2.6.2 | Allowed Option                          | Cannot be a 1+ or derivative of another user. No duplicates with other user codes | Disabled                                      | Disabled                    |
| Cross Zoned (Zone Option)                                                                                                                                                   | 4.3.1             | Required Option                         | Violation of a zone defined as Cross zone requires verification by another zone   | Enabled and two (or more) zones programmed    | Disabled                    |
| Cross Zone Verify Time                                                                                                                                                      | 4.3.1             | Allowed                                 | Programmable from 1 to 255 seconds.                                               | Time based on walk path in protected premises | 30 Seconds                  |
| Single Alarm Lockout (Swinger Shutdown)                                                                                                                                     | 4.3.2             | Required (programmable)                 | For all non-fire zones, shut down at 1 trip.                                      | Enabled                                       | Enabled                     |
| Fire Verified Zone Definitions (Fire Alarm Verificatoin)                                                                                                                    | 4.3.3             | Required Option                         | Depends on Panel and Sensors                                                      | Enabled unless sensors can self-verify        | Disabled                    |
| Call Waiting Cancel ***                                                                                                                                                     | 4.5               | Required                                | Call waiting cancel prefix code may be dialed on initial attempt ONLY.            | Depends on User Phone Line                    | Blank - Not Programmed      |

\* Programming at installation may be subordinate to other UL requirements for the intended application.

\*\* Combined Entry Delay and Abort Window should not exceed 1 minute.

\*\*\* Feature is pre-defined in the panel software and may not be altered.

# Appendix F - Regulatory Agency Statements

The ELK-M1 complies with Australian Communications Authority (ACA) regulations. On the front nameplate of the main control board is a label that contains, among other information, the C tick certification number and on the outside of the main housing, as per regulations ringer equivalence number (REN) for this equipment. If requested, this information must be provided to the telephone company. This equipment uses an Mode 3 socket to connect to the telephone network. The REN is used to determine the quantity of devices that may be connected to the telephone line. Excessive REN's on the telephone line may result in the devices not ringing in response to an incoming call. Typically, the sum of REN's should not exceed five (5.0). To be certain of the number of devices that may be connected to a line (as determined by the total RENs) contact the local telephone company.

If the ELK-M1 equipment causes harm to the telephone network, the telephone company will notify you in advance that temporary discontinuance of service may be required. But if advance notice isn't practical, the telephone company will notify the customer as soon as possible. Also, you will be advised of your right to file a complaint with the ACA if you believe it is necessary. The telephone company may make changes in its facilities, equipment, operations, or procedures that could affect the operation of the equipment. If this happens, the telephone company will provide advance notice in order for you to make the necessary modifications in order to maintain uninterrupted service. If trouble is experienced with this equipment, please contact Ness for repair and warranty information. Ness Security Products, 4 / 167 Prospect Hwy, Seven Hills, NSW, 2147 (02) 8825 9222. If the trouble is causing harm to the telephone network, the telephone company may request you remove the equipment from the network until the problem is resolved.

There are no user serviceable components in this product. All necessary repairs must be made by the manufacturer. This equipment cannot be used on telephone company-provided coin service. This equipment is hearing-aid compatible.

The ELK-M1 complies with Part 15 of FCC Rules which are designed to provide reasonable protection against such interference in a residential installation. The FCC requires the following statement for your information:

This equipment generates and uses radio frequency energy and if not installed and used properly, that is, in strict accordance with the manufacturer's instructions, may cause interference to radio and television reception. It has been type tested. However, there is no guarantee that interference will not occur in a particular installation. If this equipment does cause interference to radio or television reception, which can be determined by turning the equipment off and on, the user is encouraged to try to correct the interference by one or more of the following measures:

- \* If using an indoor antenna, have a quality outdoor antenna installed.
- \* Reorient the receiving antenna until interference is induced or eliminated.
- \* Move the receiver away from the security control.
- \* Move the antenna leads away from any wire runs to the security control
- \* Have the security control plugged into a different outlet so that it and the receiver are on different branch circuits.

If necessary, the user should consult the dealer or an experienced radio/television technician for additional suggestions. The user shall not make any changes or modifications to the equipment unless authorized by the Installation Instructions or Users Manual. Unauthorized changes or modifications could void the user's authority to operate the equipment.

## UNDERWRITERS LABORATORIES UL INFORMATION

- \* For 24 hours of standby power using two (2) 8 Ah batteries, limit auxiliary power load to 330 mA.
- \* For 4 hours of standby power using one (1) 8 Ah battery, limit auxiliary power load to 1 A.
- \* Force Arming and Auto Arming shall not be enabled
- \* For residential fire applications the indicating devices shall be a Wheelock 34T-12 or equivalent.
- \* Initiating and indicating devices must be rated at 11.5 to 12.4 VDC for residential applications and 12.0 VDC for commercial applications.
- \* When using partitioning in Commercial Burglary applications, the main control must be protected by a 24-hour alarm circuit
- \* For residential applications the minimum alarm cutoff time for the audible devices shall be 4 minutes. For commercial burglary applications the minimum alarm cutoff time for the audible devices shall be 15 minutes.
- \* Ringback shall be enabled on UL commercial burglary installations.
- \* On commercial burglary installations the fire initiating circuits shall not be connected.
- \* Zone Swinger Shutdown shall not be enabled.
- \* Total combined continuous current draw from terminals +SAUX, +VAUX, +VKP, Out2, and connector J16 is ?? Amps.
- \* Remote Downloading shall not be used on UL Listed systems.
- \* Communicator Dial Delay time shall be set to "0".
- \* For residential burglary applications the maximum entry delay time shall be 45 seconds and the maximum exit delay time shall be 60 seconds. For commercial burglary applications the exit delay time shall not exceed 60 seconds.
- \* The keyswitch option shall not be used.
- \* 24-hour communicator test transmission is required.
- \* The silent keypad option shall not be enabled.

## MINIMUM SYSTEM CONFIGURATIONS FOR UL INSTALLATIONS (Residential Burglary, Residential Fire, Commercial Burglary)

- \* The Digital Alarm Communicator Transmitter DACT shall be enabled for all commercial burglary applications.
- \* At least one compatible keypad is needed for all applications.
- \* At least one bell fixture is required for all applications, except Grade C Central Station. For Grade A Local, the AD10-12 Bell and Grade A bell housing shall be used.
- \* The wireless devices are only UL listed for residential applications

[Intentionally left blank]

# Appendix G - Additional Keypad Information

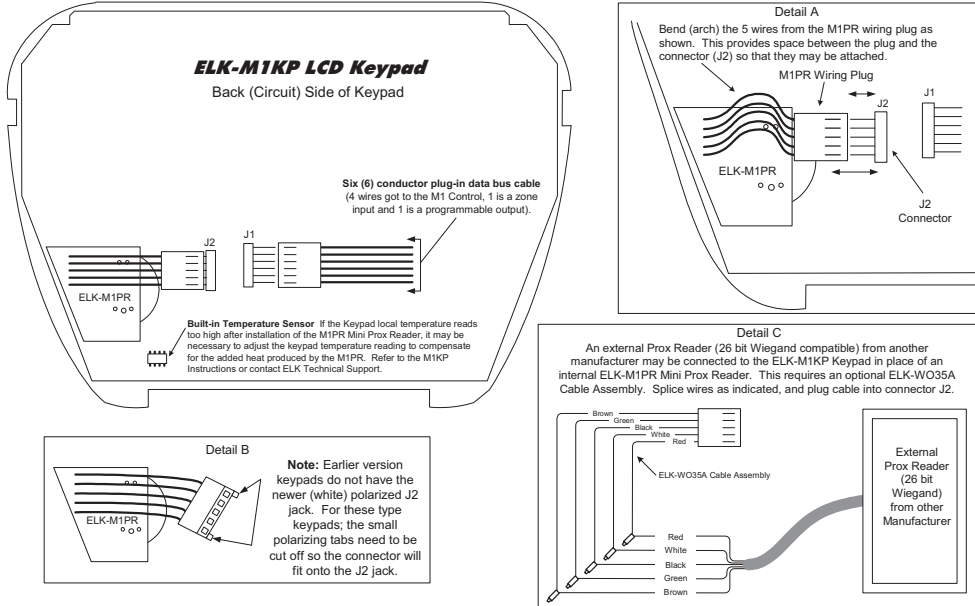

## Installing a ELK-M1PR internal prox reader or an external (26 bit Wiegand) prox reader

(Note: if connecting external readers, such as the Ness IDTeck or Ultraprox reader, use the W035A (Ness part # 101-221) connection cable)

1. Turn Off the M1 Master Power Switch.
2. Remove M1KP Keypad from mounting plate, disconnect the 6 pin data bus cable, and place face down on a soft surface.
3. Locate the 1" mounting hole in the lower left corner and the 5 pin connector marked J2 to the right of the mounting hole.
4. Position the M1PR in the 1" mounting hole with its 5 wire female cable facing towards connector J2 on the circuit board.
5. Gently lift up on the 5 wire cable, then bend the white plug down to form a slight arch in the wires.  
**SEE DETAIL A.** This will shorten the cable enough that it can be plugged into connector J2.
6. Reconnect the 6 pin data bus cable to connector J1 and install the keypad onto its mounting plate.
7. Turn On the M1 Master Power Switch and follow the instructions for enrolling cards or fobs

## Enrolling Prox Cards and Fobs

Prox cards/fobs are enrolled into a User Code location using the same procedures used to add/change User Code PINs.

1. Press the ELK key, then press the 6 key (or scroll up) to display 6 - Change User Codes. Press the RIGHT arrow key to select this menu. A Master user code (PIN) must be entered to gain access to this menu.
2. Enter the three digit number of the desired User Code location (001 to 099) or use the UP or DOWN arrow keys to scroll through the codes. Then select CHG by pressing the RIGHT arrow key.
3. The keypad will display any existing 4 or 6 digit code that is programmed for this user along with any programmed name.
4. Place a new (not previously enrolled) prox card/fob near the Keypad's right speaker grill below the Stay key. The read range is approximately 1/8" to 3/8". The Keypad should beep 3 times and display the card/fob 12 digit ID.
5. If the card/fob is rejected, a low error tone and Code Not Authorized, Redo will display. Causes for reject include: A. The card/fob has already been enrolled (duplicate codes are not allowed) OR B. The facility code in the card/fob does not match the reader facility code. A prox reader can only read cards/fobs with a matching facility code.
6. Once a prox card/fob is enrolled in a user code location, its capabilities are set by the User Code Options found in Installer Menu 02. The commonly used options are: Arm the M1 Control, Disarm the M1 Control, or Access event.

A keypad access event occurs when a valid prox card/fob is read at a keypad. Nothing will happen until this event is utilized in a Whenever/And/Then Rule from the Ness-RP software. An Access event can be used to create virtually any desired reaction. i.e., turn on an output, a light, close/open a relay, etc. The following rule example turns on Output 003 for 10 seconds when a valid prox card/fob (with Access Option enabled) is read at Keypad 01. This could be used to break power to a door strike.

**WHENEVER Keypad 01 Access is Activated  
THEN Turn On Output 003 for 10 seconds.**

# Appendix G - Additional Keypad Information (cont.)

## KEYPAD INTERNAL TEMPERATURE SENSOR

Every standard M1KP has a built-in temperature sensor, which detects the surrounding ambient temperature. The sensor temperature may be displayed on the LCD, and read from another keypad or the telephone remote control. It may also be used with the Ness-RP Whenever/And/Then Rules to automatically cause an action or control something. i.e., a fan, pump, light, etc.

### Viewing a Keypad temperature sensor reading

1. To view a keypad temperature sensor press the ELK key once (enter code if prompted), then press the RIGHT arrow to select the View/Control Automation menu.
2. Press the 5 key (or scroll up) to display: 4-Keypad Temperature, then press the RIGHT arrow key.
3. The first Keypad (Keypad 01 will be displayed along with its Name, Keypad Number, and Temperature.
4. Additional Keypad Temperature sensors (if any) may be displayed by entering the 2 digit Keypad number OR by scrolling with the UP or DOWN arrow keys. To exit from this menu press the \* key.

### Using a Keypad temperature reading in a Rule to create an action or output

The following is an example of a Ness-RP Whenever/And/Then Rule to automatically turn on Output 3 (controlling a Fan, etc.) for 10 minutes whenever the Keypad temperature reading exceeds 90 degrees.

1. Start RP and open an account. Click the Automation tab and the Rules tab followed by New.
2. Click Trigger, then point to Time Occurrence, then Every X Seconds, and then click to select. \*\*
3. In the block beside the words Fixed Value, type in 30 and click OK.
4. Click And, followed by Temperature which is located near the bottom of the drop down list.
5. Highlight the Keypad temperature sensor (by name), click the Greater than button, and change the temperature selection number to 90. Make sure the button beside F is selected, and click OK.
6. Click Then, followed by Turn Output On/Off. Highlight Output 3 (use the scroll down arrow), make sure the button beside Turn on is selected, then select the box labeled For. Highlight the hrs:mins:secs window and enter 00:10:00 (10 minutes). Click OK. Double check everything and click Done.
7. The completed Rule should resemble the example below.

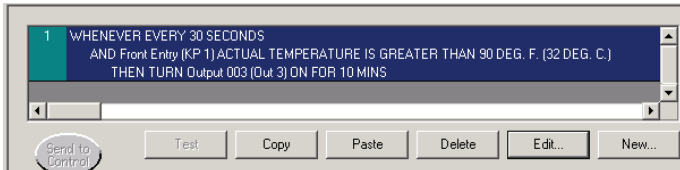

\*\* Numerous triggers may be used for a temperature type rule, i.e., time occurrence, arming of the security system, opening of a zone, etc. However, the M1 does not allow a temperature reading to be used as a trigger. This helps prevent a false activation "runaway" that could occur simple because the temperature has fluctuated by a degree or fraction of a degree. Instead, the AND command is used to compare or "test" a temperature sensor reading against a target value, each time the trigger occurs. The target value is programmable and the compare options are "Equal to, Not equal to, Less than, and Greater than". The "Equal to" is not recommended as a compare option because it may be impossible for a temperature reading to be exactly at the target value when the trigger occurs.

## TEMPERATURE READING ADJUSTMENT

If the Keypad internal temperature sensor appears to read higher or lower than other room thermostats/thermometers, it may be due to the Keypad mounting location, the room conditions, or the installation of an optional Mini Prox Reader (M1PR). The Keypad has an adjustment procedure which allows compensation for these conditions.

1. Press and hold the " \* " key, followed by the F5 key . HOLD BOTH keys pressed for 5-10 seconds or until the LCD displays **Exit when done. F1 Set Addr.** (This is Keypad setup mode)  
NOTE: This mode may also be accessed by removing power from the keypad (unplugging the data bus cable) and then applying power while holding any key pressed.
2. Press the F2 key and the LCD will display: **Temperature Degrees F = XX.X** (This is the current temperature)
3. Use the UP or DOWN arrow keys to adjust the current temperature display until it approximates the desired setting. Each press of the arrow keys changes the setting by approximately 3 tenths of a degree (00.3) It may not be possible to end up exactly on an even temperature setting.
4. Press the Exit key twice do return back to the regular operation mode.

## M1 LIMITED WARRANTY

The Ness-M1 and its associated component products are warranted by Ness security Products ("Ness") against defects in material and workmanship for a period of Two (2) years from the date of purchase. If a product is found to be defective during the first 180 days, Ness may allow an over the counter exchange, subject to inspection and approval by one of it's authorised staff. Ness's obligations under this Limited Warranty shall be limited to repairing or replacing, at its option, free of charge, during this warranty period, any product returned to Ness freight prepaid. After the expiration of the warranty period, product will be repaired or replaced based on a fixed charge per device.

Ness shall have no obligation under this Limited Warranty or otherwise if (1) the Product has been damaged by negligence, accident, mishandling, lightning or flood, or other Acts of God, (2) the Product has not been operated in accordance with its operating instructions, (3) the Product has been altered or repaired by anyone outside Manufacturer's authorized facilities (4) adaptations or accessories have been made or attached to the Product which, in Ness's sole determination, have adversely affected its performance, safety or reliability, (5) accessories other than those recommended by Ness are used on the system.

If a Product should malfunction or fail during it's warranty period then ALL returned products must include a complete description of the problem otherwise a repair charge maybe applicable even if the product is under the warranty period. Ness will not be responsible for any unnecessary items included with any returned Product.

THIS WARRANTY IS THE EXCLUSIVE WARRANTY FOR ANY PRODUCT. NESS SPECIFICALLY DISCLAIMS ANY AND ALL OTHER WARRANTIES OF ANY KIND, EXPRESS OR IMPLIED, INCLUDING ANY WARRANTIES OF FITNESS FOR A PARTICULAR PURPOSE OR OF MERCHANTABILITY. NESS SHALL NOT BE LIABLE IN TORT, INCLUDING NEGLIGENCE OR STRICT LIABILITY, AND SHALL HAVE NO LIABILITY AT ALL FOR INJURY TO PERSONS OR PROPERTY. NESS'S LIABILITY FOR FAILURE TO FULFILL ITS OBLIGATION UNDER THIS LIMITED WARRANTY OR ANY OTHER LIABILITY IN CONNECTION WITH A PRODUCT SHALL BE LIMITED TO THE AMOUNT OF THE PURCHASE PRICE RECEIVED BY NESS FOR THE PRODUCT. THE REMEDIES STATED IN THIS LIMITED WARRANTY ARE THE CUSTOMER'S EXCLUSIVE REMEDIES AGAINST NESS REGARDING ANY PRODUCT. UNDER NO CIRCUMSTANCES SHALL NESS BE LIABLE FOR ANY INDIRECT, INCIDENTAL, SPECIAL OR CONSEQUENTIAL DAMAGES, INCLUDING LOST PROFITS AND REVENUES, INCONVENIENCE OR INTERRUPTIONS IN OPERATIONS, OR ANY OTHER COMMERCIAL OR ECONOMIC LOSSES OF ANY KIND. THESE LIMITATIONS AND DISCLAIMERS ARE NOT MADE BY NESS WHERE PROHIBITED BY LAW.

# Index

## A

Alarm Abort 40  
Alarm Cutoff Timers 33  
Anti-Takeover 21  
Area Partitioning 21  
Area Reporting Codes 40, 41  
Auto Stay Option 27  
Automation control function 16  
Automation Tasks 51  
Auxiliary Power Connections 10

## B

Battery Connection 10  
Bus Module Enrollment 25

## C

Central Station alarm verification 36  
Communicator Setup Checklist 22  
Comparisons of M1 and M1G (Gold) 5  
Counters 53  
CrossZonePool 33  
CrossZoneVerTime 35  
Custom Settings 53  
Custom voice messages  
    Voice message recording 19

## D

Data Bus Device Types/Addresses 24  
Daylight Savings Time 35  
Defaulting the Control 36  
Dialer Delay 33  
Dialer Delay Time 41  
Duress 24

## E

Entering Installer Level Programming 22  
Entry delay time 26  
Event Codes - Appendix A 58  
Exit delay time 26  
Exit Error 26  
Exit TimeRestart 27  
Exit1TimeRestart 27

## F

Force Arm 32

## G

Global Sys Definitions 34, 35, 36, 37

## I

Input/Output Expander Addresses 24  
Installation and Wiring 8  
Installer Program Code 14, 16, 22, 25

## K

Keypad Addresses 24  
Keypad Definitions 29  
Keypad Menus 16

## L

Lighting 52  
Listen-In 33

## M

Menu 01 - Bus Module Enrollment 25  
Menu 02 - User Code Authorities 25  
Menu 03 - Area Definitions 27  
Menu 04 - Keypad Definitions 28  
Menu 05 - Zone Definitions 30  
Menu 06 - Alarm Cutoff Timers 33  
Menu 07 - Global System Definitions 34  
Menu 08 - Telephone Account Setup 38  
Menu 09 - Area Reporting Codes 40  
Menu 10 - Zone Reporting Codes 42  
Menu 11 - Sys Report Code Options &  
    Codes 43, 44  
Menu 12 - User Report Codes 47  
Multi-area (Partition) Operation 20

## O

Operating The System 14  
Output 1 Delay Turn-On 34  
Outputs 11, 52

## P

Periodic Trip 33  
Prox Reader 68

## Q

Quick Reference Programming Guide 23  
Quickarm 26

## R

Regulatory Agency Statements -  
    Appendix F 66  
Ring/Hang/Answer option 36  
Rings Until Auto Answer 37  
RP Software 49

Rules 55

## S

Serial Port Baud Rate 37  
SIA CP-01 Compliance - Appendix E 65  
Silent Alarm 31  
SingleAlmLockout 37  
Specifications, Features, and Benefits 5  
Sunrise/Sunset 52  
SwingerShutdown 33  
Sys Rpt Code Options 44, 45

## T

Tasks 51  
Telephone Account Setup 38, 39  
Telephone Line Connection 11  
Telephone Remote Control 34, 60  
Temporary Code 24  
Texts 54  
Thermostats 54  
Transformer Power Input (AC) 10  
Two Way Listen-in 36

## U

Update/Verify Firmware 50, 51, 74  
User Code 14, 16  
User Code Options 24

## V

Verify Call Time 37  
Voice Dialer 38  
Voice messages - Recording Custom 19  
Volume level adjustment 35

## W

Whenever/And/Then 55  
WirelessDefinitions 47  
Wiring & Hookup Diagram 6  
WrongCodeLockout 35

## Z

Zone Definitions 31, 32  
Zone Reporting Codes 42, 43  
Zone Wiring Types 31



## Ness M1 Installation & Programming Manual

Document Part No: 890-013

Revised April 2013

[www.nesscorporation.com](http://www.nesscorporation.com)

National Customer Service Centre

Ph: 1300 551 991

[customerservice@ness.com.au](mailto:customerservice@ness.com.au)



All rights reserved. No part of this publication may be reproduced, transmitted or stored in a retrieval system in any form or by any means, electronic, mechanical, photocopying, recording, or otherwise, without the prior written permission of Ness.

Ness reserves the right to make changes to features and specifications at any time without prior notification in the interest of ongoing product development and improvement.

© 2013 Ness Corporation Pty Ltd ABN 28 069 984 372